

# GEIS

## SecoVac 40.5kV Vacuum Circuit Breaker & SecoVac 40.5kV Medium Voltage Metal-Clad Switchgear

GEIS Electrical Protection

Safer Smarter Greener



## About GEIS

GEIS was established in 2019 following the spin-off of several businesses and assets that ABB had acquired from GE on July 1, 2018, including 3 manufacturing centers, Warehousing & Trading business at FTZ, China Technology Center.

- Components: Full range of circuit breakers up to 40.5kV: Medium voltage vacuum circuit breakers, LV circuit breakers: ACB, MCCB, MCB, RCD, RCBO: Control components.
- Equipment: MV switchgear (Air insulation and Gas Insulation Technology), LV switchgear, switchboard.
- Medium voltage distribution transformer.
- Medium voltage ATS system (Paralleling Switchgear).

After the separation, all the above product lines were rebranded as AEG for selected markets and GEIS for global markets. Moreover, GEIS has expanded its technological portfolio to include medium-voltage controls such as VFDs and soft starters, as well as ATS systems and EV chargers.



# Quality is Built-in

## Where Technology Meets Manufacturing Excellence for Customers

- Since 2000, we have been specializing in localizing world-class products and manufacturing technologies, developing strong expertise and a highly capable team.
- Vertical integrated Shanghai Manufacturing Center brought key manufacturing processes into a 75,000 m<sup>2</sup> facility, enabling high-quality, high-efficiency production and fostering innovation. A dedicated R&D team committed to developing products that meet global standards and serve diverse applications.
- Global expansion: GEIS's first Thailand facility makes it easier to serve customers worldwide.



## GEIS deliver complete range of products for the evolving electrification needs:



**SecoVac VCB**



**M-PACT Plus ACB**



**Elfa Series MCB/RCBO**



**SolidDrive MV VFD**



**SecoGear MV Switchgear**



**RMU Gas Insulated Switchgear**



**WaveCast Transformer**



**MLS LV Switchgear**

# Vacuum Circuit Breaker & Medium Voltage Metal-Clad Switchgear

## Catalogue

**A**

### Product profile

- A.1 Predominant Vacuum Technology
- A.2 Product Performance Features
- A.3 Breaker Features
- A.4 Panel Features
- A.6 Instrument Transformer

**B**

### Technical Data

- B.1 Technical Data of SecoVac
- B.2 Technical Data of SecoGear Switchgear
- B.3 Normal Service Conditions

**C**

### Overall Dimension

**D**

### Internal Wiring Diagram

**E**

### Primary Scheme of SecoGear

**F**

### Combinated Scheme

**G**

### Installation of Switchgear

**Predominant Vacuum Technology**

Vacuum interrupting technology is nowadays the dominant switching principle in medium voltage. Innovative developments are leading to a continuously increasing market growth, based on the fundamental advantages such as reliability, availability, compactness and, last but not least, the environmental responsibility of the vacuum as a switching medium.

**Vacuum Interrupter**

The switching element of the vacuum circuit-breaker is the vacuum interrupter. It consists of an arc chamber, which is located between two ceramic insulators. Terminal studs connect the contacts to the external terminals. One contact is fixed within the housing, the other one is moveable. The metal bellows enable the contact movement and provide a hermetic connection to the interrupter housing. The contact stroke is only a few millimeters. The internal pressure in the vacuum interrupter is less than  $10^{-7}$  bar. The vacuum circuit-breaker has no arc-quenching medium. The properties of the contact material and the contact geometry define the switching behavior and the switching capacity.

After contact separation, the resultant arc evaporates contact material from the contact surfaces. The arc current thus flows through a material vapour plasma until the next current zero. Near the current zero, the arc is extinguished and the metal vapour loses its conductivity within a few microseconds as a consequence of the recombination of the charge carrier ions. In this way, the contact gap is de-ionized and the dielectric strength restored very fast. The metal vapour condenses on the contact surfaces. Only a very small portion condenses on the arc chamber wall. The arc chamber wall has the function of a vapour shield, to prevent condensation of the metallic vapour onto the insulators.

**Unique and Proven Embedded Pole Technology**

SecoVac series MV embedded pole vacuum circuit breaker uses the latest and mature technology of Automatic Pressure Gelation IAPGI to embed the vacuum interrupter and connection terminals within epoxy resin. The vacuum interrupter is cast in the epoxy resin, without screw fixation which can cause the concentrated harsh electrical field and result in decrease of the electrical insulation strength of the pole. Thanks to the embedded pole technology, the assembly of the pole is simplified, and the assembly accuracy as well as quality of the embedded pole is easily to be controlled by the state of the art production process. The embedded pole technology will also improve the environmental resistant capability of the breaker, as the primary circuit of the breaker is completely embedded inside the epoxy resin, the risk of insulation fault caused by adverse operating environment such as dust, humidity, vermin, polluted ambient and high altitude operating site are eliminated thoroughly.

The key know how of the embedded pole technology is the buffering layer between epoxy resin and ceramic housing of vacuum interrupter, where the material and processing of the buffering layer is essential to ensure the integrity of epoxy resin of the embedded pole provide adequate adhesion between each other in any circumstance. Our patented LSR (Liquid Silicon Rubber) buffering layer and double APG (Auto Pressure Gelation) process adopted in the producing of the embedded pole thoroughly eliminates the cracking of the epoxy resin caused by the large difference of thermal expansion coefficient between epoxy resin and ceramic in case of rapid changing of the ambient temperature. APG process for LSR buffering layer ensures that there will not be any air gap or bubble between the buffering layer and ceramic housing, hence, the high electrical insulation strength of the embedded pole of SecoVac series MV embedded pole vacuum circuit breaker is guaranteed.

The partial discharge value of embedded pole manufactured by our patented LSR (Liquid Silicon Rubber) buffering layer and double APG (Auto Pressure Gelation) process is below  $5\text{pC}$  with an applied testing voltage of  $1.2\text{Um}$ .

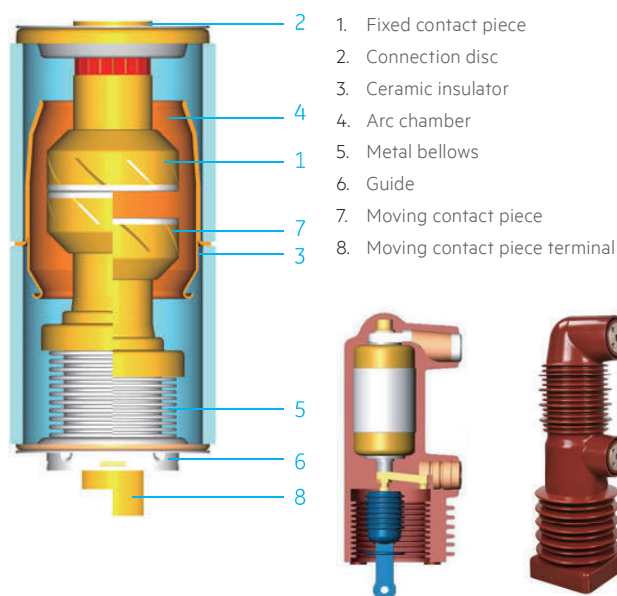

## Product Profile

### Product Performance Features

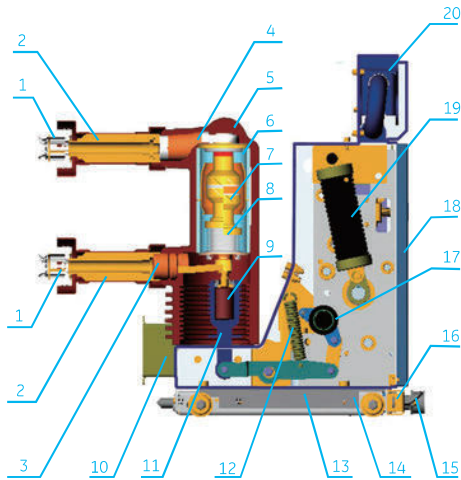

1. Tulip Contact	11. Insulated Coupling Rod
2. Contact Arm	12. Opening Spring
3. Lower Contact Terminal	13. Earthing Contact of Cart
4. Upper Contact Terminal	14. Classis of Car
5. Embedded Pole	15. Hole for Driving Screw
6. Vacuum Interrupter	16. Locking Piece
7. Moving contact pieces	17. Operating Shaft
8. Metal Bellows	18. Operation Cover
9. Disc Spring for Contact Pressure	19. Closing Spring
10. Shutter Driving Plate	20. Secondary Plug

### Brilliant VCB and Switchgear

#### Modular Operation Mechanism

SecoVac series MV embedded pole vacuum circuit breaker is equipped with modularized, standardized and simplified operating mechanism, the mechanism consists of separated closing and opening modules, all the mechanical parts of the mechanism are integrated into these two modules. The closing and opening modules are universal to whole series of SecoVac embedded pole vacuum circuit breaker regardless of ratings. It means there is only one kind of closing and opening module for the whole SecoVac products family, thanks to such a design, the maintenance time and cost for the mechanism is low, and the replacement of modules can be easily carried out on site. There is no impact on the original dynamic characteristic of the breaker after the replacement of modules. After replacement of modules, the test should be applied. Another feature of the operating mechanism of SecoVac series MV embedded pole vacuum circuit breaker is that the total number of parts of the mechanism is reduced compared with the traditionally designed mechanism, so that the reliability of the mechanism is enhanced significantly.

The opening damper of the mechanism plays a very important role to ensure reliable performance and high mechanical endurance of SecoVac series MV embedded pole vacuum circuit breaker. By adoption of the opening damper, the overtavel and re-bounce of moving contacts of vacuum interrupters during the opening of this VCB is reduced to a minimum. The lower overtravel of the moving contacts means lower mechanical stress to the bellow of the vacuum interrupter, so the designed mechanical endurance of the vacuum interrupter is guaranteed. The lower re-bounce of the contact ensures low arc re-striking probability during the breaking of capacitive current, so the occurrence rate of operating overvoltage is reduced.

#### Integrity, Flexibility and Reliability

SecaGear is designed, assembled and tested to meet or exceed applicable IEC standard. It incorporates the compartment concept with grounded metal barriers that segregate primary functions so that no live parts are exposed. Safety interlocks are standard, as are closed door racking and storage, breaker position indicator, and positively actuated safety shutters. SecoGear reliability is based on the usage of proven components. All components including the advanced SecoVac embedded pole vacuum circuit breaker, insulating materials, disconnect bushings, inter-unit bushing and instrument transformers have been strictly selected and have been qualified for 40 years lifetime through accelerated thermal aging tests. Combining the time-honored advantages of General Electric metal-clad switchgear—flexibility, quality and economy—with vacuum interruption's longer life, design simplicity, smaller size and weight, and reduced maintenance, SecoGear has built its own tradition of superiority.

#### The State of the Art Processing and Advanced Quality Control

The high quality of the embedded pole is achieved by using the latest APG (Auto Pressure Gelation) technology and advanced vacuum mixing and degassing technology that are carried out by the equipment. The Vogel clamping machine is an essential piece of equipment to ensure the mechanical and insulating strength of the embedded pole of SecoVac series MV embedded pole vacuum circuit breaker.

As well as the processing facilities, the testing facilities are also very important to the quality control of the breaker. In the manufacturing Process of SecoVac VCB, from incoming material quality control to the final inspection and testing, every step is strictly calibrated and tested by means of testing facilities.

**Breaker Features**

**Front Panel**

This front panel fits into a collar-frame in the equipment when the breaker is in the CONNECT position. It provides a metal barrier between the breaker compartment and the secondary device compartment. Well marked and easy-to-read operating controls and indicators include TRIP button, CLOSE button, OPEN/CLOSE indicator, CHARGE/DISCHARGE indicator, OPERATIONS counter and provision for manual charging the breaker.



**Breaker Mechanism**

All the mechanical parts of the mechanism are integrated into opening and closing modules individually. The closing and opening modules are universal to whole series of SecoVac embedded pole vacuum circuit breaker in spite of the ratings. Such design assures no mechanical readjustment after the replacement, thereby not only shortens lead-time but also reduces operation and maintenance cost.

**Primary Disconnect**

The primary disconnect finger set is rugged and easy to inspect, designed for optimum contact, built of silver-plated copper and tested for continuous and short time current. Cycloid design is more convenient to connect and expand wider contact area than flat design. These disconnects provide proper contact integrity throughout the life of the gear for the critical primary disconnect function.



**Interlock System**

For personnel safety, SecoVac is designed with a number of mechanical and electrical interlocks. For example, breaker contacts must be open before the breaker can be moved to or from the CONNECT position. A positive mechanical stop is provided when the breaker reaches the CONNECT or TEST/DISCONNECT positions. Mechanical interlocks are provided to permit only the insertion of properly rated breakers into any specific compartment. These and other necessary interlocks provide a comprehensive protection system. Furthermore, springs automatically discharge when the breaker is withdrawn from the CONNECT position and breakers cannot be inserted in the closed position.

## Product Profile

### Panel Features

#### LV Compartment

Located right above the cabinet, the compartment is equipped with component installation lattice inside to facilitate the installation of the relays. Wiring terminals and small busbar terminals can be installed at the bottom of the compartment. On the right and left side plate, there are holes at the place corresponding to the terminals for the coupling of small busbars between the cabinets. On the door of the compartment, there are electronic analog indicators for the main circuit to indicate the actual positions and status of the breaker, truck and earthing switches. Comprehensive protections and other control and operation devices can also be installed on the door to realize the function such as remote control, remote monitor and remote communication and local monitor.

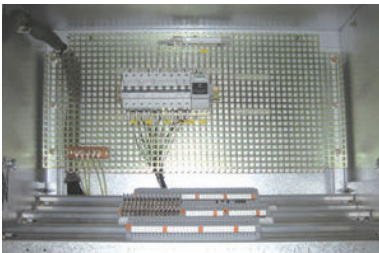

#### Cable Compartment

Located at the lower rear part of the cabinet, the compartment has separate pressure-relief passage. At the bottom of it, there are cable clips and covers for passing and fixing the primary cables. The cable connection terminal can be up to 680mm from the ground. The rubber cable bushing at the bottom of the compartment can be bored according to the diameter of the actually passed cables to ensure the partition of the compartment from the cable chutes. Normally, 180mm<sup>2</sup> single core cross-linked cables can be installed, 4 pieces for each phase and 12 pieces in total as well as 400mm<sup>2</sup> single core cross-linked cables, 2 pieces for each phase and 6 pieces in total. Based on the requirement, earthing switches and zinc oxide arrestors can be installed in the compartment with reliable mechanical interlock between the earthing switches and the rear cover plate.



#### CB Compartment

Located in the front of the cabinet, the compartment is equipped with Pressure relief on the top and six transformer-contact box module apparatus on the back. Inside the compartment, there is metal foldable protection movable door that opens or closes by driving the chain wheel with the chain. When the truck is moving from the test position toward the working position, the movement of the truck can be observed from the glass window on the front door. The position of the truck is to be indicated on the position switch. On the right upper part, there is an auxiliary socket with 64 cores, which is connected with the secondary plug of the breaker and controlled by mechanical interlock. When the breaker is at the working positions, the secondary plug can not be pulled out. On both sides of the compartment, there is secondary cable passage leading directly to the instrument compartment. There are openings on the door of the compartment for closing the door, emergent breaking and the crank of the truck to ensure the safety of the operators.



#### Busbar Compartment

Located at the upper rear part of the cabinet, the compartment is equipped with a pressure-relief window on the top. Between the neighboring cabinets, there are metal diaphragms as well as epoxy wall penetration bushing and rubber gaskets for passing the main busbar. Tube busbar is selected for SecoGear. The main busbar current capacity is more than other traditional rectangle busbar. Thanks for this unique design, the skin effect is weaker thus we avoid more power loss while operating; this tube busbar also helps SecoGear realize larger creepage distance than IEC required, which assures more safety and reliability.

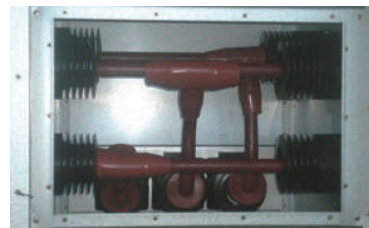

**Panel Features**

**Reliable Interlock System**

For personnel safety, SecoGear is designed with a number of comprehensive electrical and mechanical interlocks, which is declared as but not limited to:

- a. When the earthing switch is under closing condition, the truck is unable to move from the off/test position toward the working position
- b. Only when the truck is at the off/test or test/disconnect position, can the earthing switch be closed
- c. Only when the breaker is under opening condition, can the truck be moved in and out; when the truck is at the transition between the test and working positions inside the cabinet, the breaker is unable to be closed.
- d. When the truck is at the any position between the working position and the test position, the auxiliary circuit plug is unable to be pulled out. When the earthing switch is under opening condition, the cover plate on the back of the cabinet can't be opened. If the cover plate is not completely in place, the earthing switch can't be opened. When the cabinet door is closed, the truck can be moved in and out manually and the breaker as well the earthing switch can be opened and closed.

**Integrated CT with Static Contact Box**

For compact design concern, GEIS has worked out this current transformer-contact seat module apparatus that has obtained China patent right. (Seperate CT is also available as customer's requirement.) The integral current transformer for this partition contact box has a penetration construction, is composed of the iron core, primary coil and secondary coil and cast in the way of epoxy encapsulation to form the main insulation and external insulation at the same time.

The transformer can either hold two windings respectively for measurement and protection or only act as the partition insulation bushing with no secondary windings. The product is small in size, light in weight and strong in adaptability.

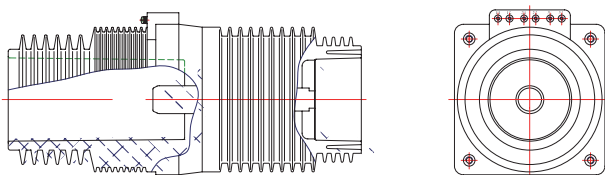
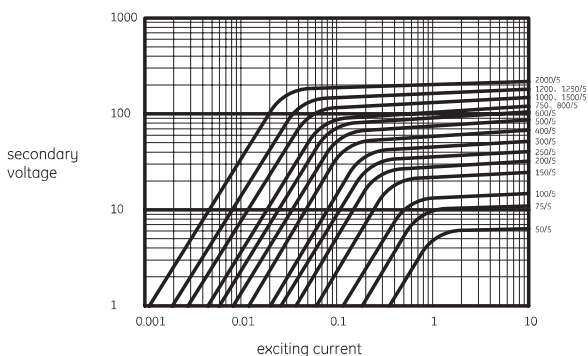

**Unique & Considerate Design - L-Frame**

Considering easier assembly for panel, GEIS offers L-Frame option for VCB application. L-Frame panel kits are manufactured to meet current medium voltage industry standards. The designs are certified, providing a modular building block approach for installation into new and existing switchgear configurations. For any special application, please contact GEIS for further solution.

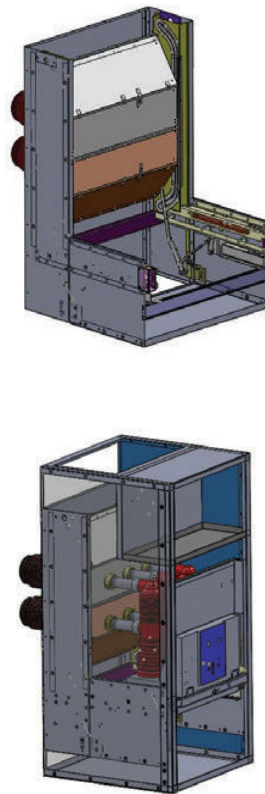

## Product Profile

### Instrument Transformer

#### Current Transformer

The current transformer and voltage transformer are cast-resin type instrument transformers for measuring devices and protection devices of indoor application at the frequency of 50 or 60 Hz.

The instrument transformers are molded in high quality epoxy resin to have a good performance at high polluted and humid area. The instrument transformer is designed to suite installation in tropical environment and it doesn't need special maintenance.

The instrument transformers can be mounted at any position. The light weight and small dimensions are the main features of its design.

The current transformer secondary terminals are located in recesses either in one or both sides of the transformer base, therefore giving two connection possibilities for installation flexibility.

A ring type CT is also available for ground protection devices.

#### Voltage Transformer

The voltage transformers can be one or two poles type, with performances and accuracy classes suited to the functional requirements of the connected devices.

When they are installed on a withdrawable truck they are fitted with primary fuses.

The current and voltage transformers are designed to meet or exceed requirement of IEC60044-1 and IEC60044-2 standards respectively.

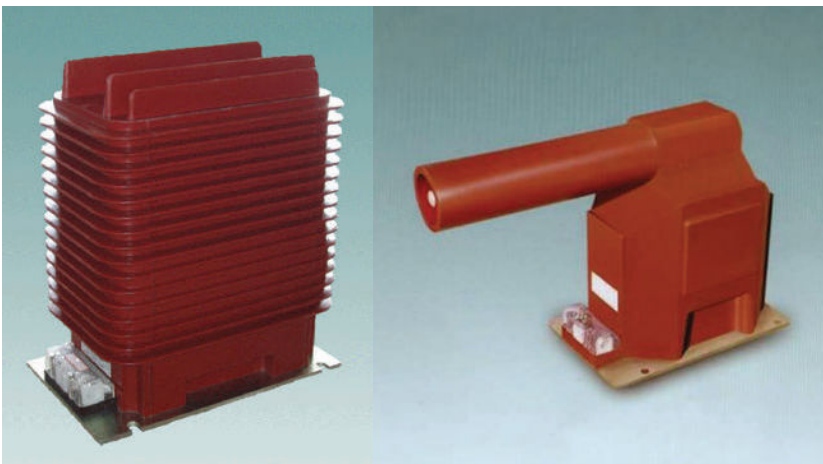

**Technical Data of SecoVac**

Description	Unit	Data
Rated voltage	kV	36/40.5
Rated current	A	1250/1600/2000/2500
Rated frequency	Hz	50/60
Rated power frequency withstand voltage (1min)	kV	95
Rated lightning impulse withstand voltage (peak value)	kV	185
Rated short circuit breaking current	kA	25/31.5
Rated short time withstand current (3S)	kA	25/31.5
Rated peak withstand current	kA	63/80
Rated peak making current	kA	63/80
Electrical endurance	No. of times	E2, IEC 62271-100
Mechanical endurance	No. of times	MI
Operating sequence	-	0-0.3s-CO-180s-CO, 0-180s-CO-180s-CO
Rated auxiliary control voltage*	V	AC 110/220; DC110/220
Opening time	ms	<40
Closing time	ms	<80

\*Other voltages are available on request

## Technical Data

### Technical Data of SecoGear Switchgear

Description		Unit	Data
Rated voltage		kV	36/40.5
Rated frequency		Hz	50/60
Rated insulation voltage	Rated power frequency withstand voltage/1 minute	kV	95
	Lightning impulse withstand voltage (peak value)	kV	185
Rated current of busbar		A	1250/1600/2000/2500
Rated current of T-off busbar		A	1250/1600/2000/2500
Rated short time withstand current (3s)		kA	25/31.5
Rated peak withstand current (peak value)		kA	63/80
Ingress protection			Panel IP4X, Compartment IP2X

\*Direct current resistance of current transformer

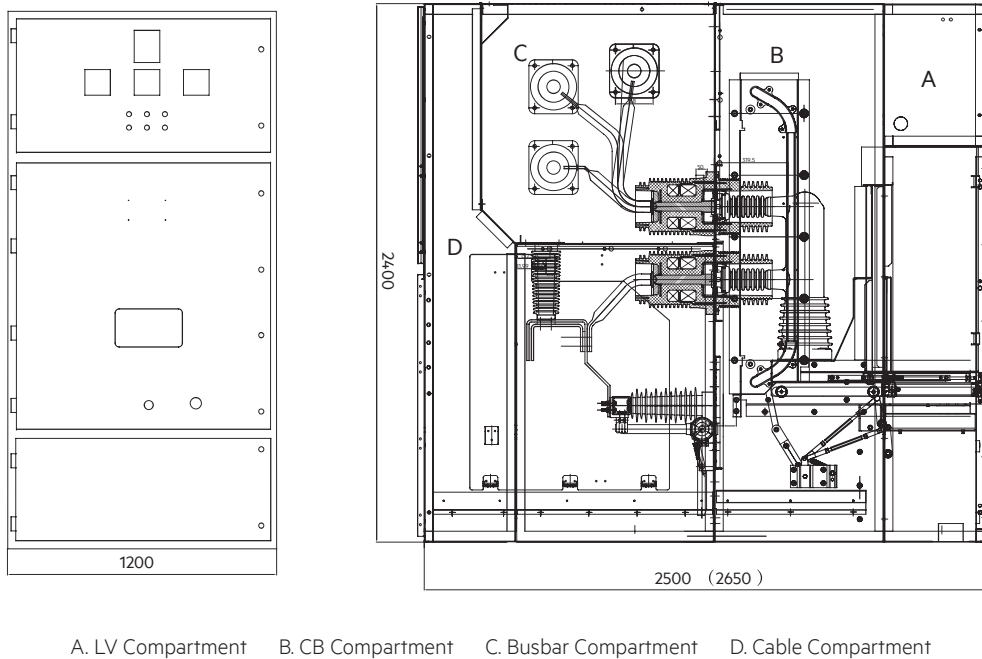

SecoGear cross section view

**Normal Service Conditions**

Ambient temperature: the temperature of the ambient air shall not be higher than +40°C and not lower than -15°C and the mean value measured within 24h shall not exceed +35°C.

Ambient humidity: The average of relative humidity measured in 24h shall not be more than 95% and the monthly average not more than 90%.

Height above the sea level shall not be more than 1000m.

Seismic intensity is not more than 8 degree.

The asperity under the operation condition free of flammable gas and fire, danger of explosion, condensation and dirt: in accordance with the specification in level 1 in IEC62271-200: 2003.

Note: when the relative humidity is above 70%, the heater shall be switched on to prevent condensation.

When the normal service condition is different from the above mentioned, please consult the manufacturer.



# Overall Dimension

## SecoVac Withdrawable

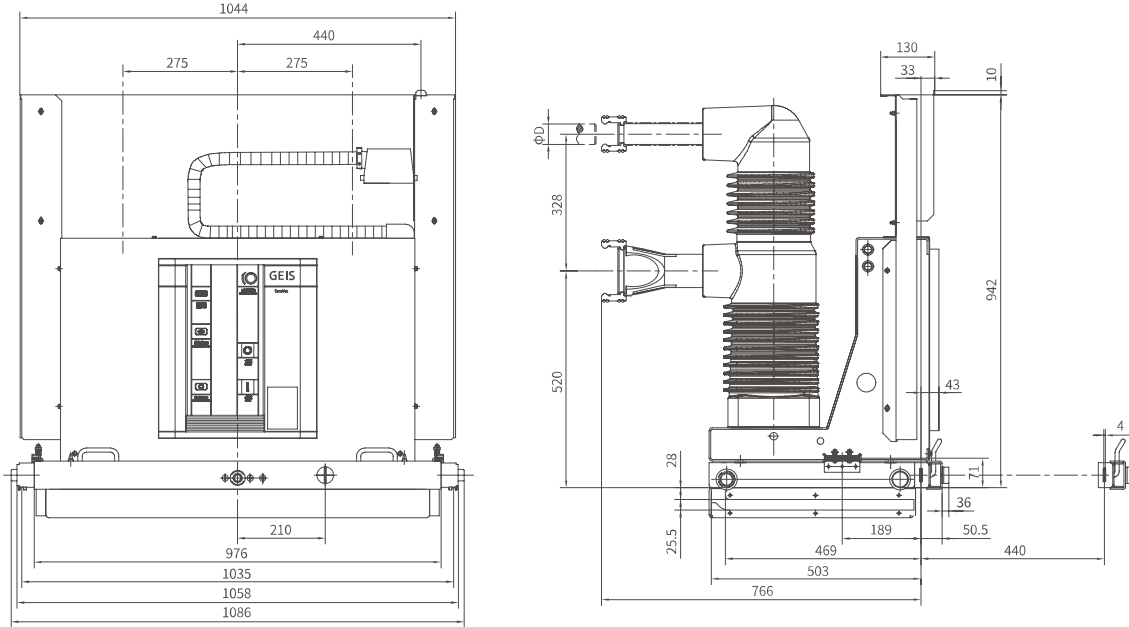

## SecoVac Fixed

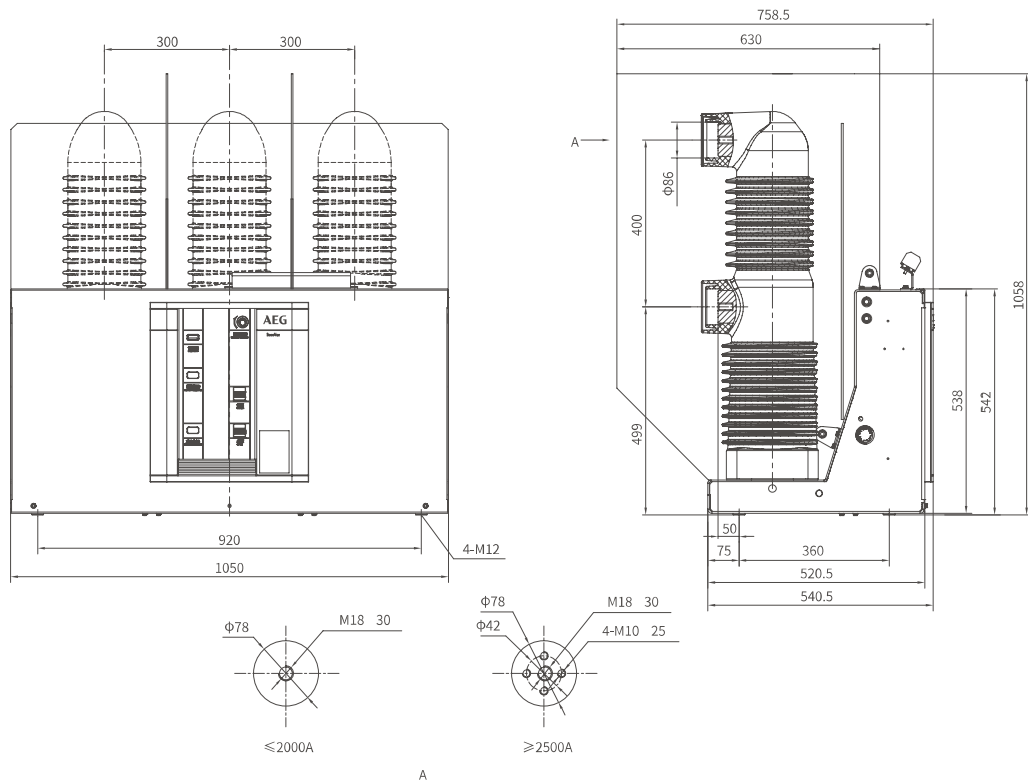

# Overall Dimension

## L-Frame for 40.5 SecoVac Withdrawable

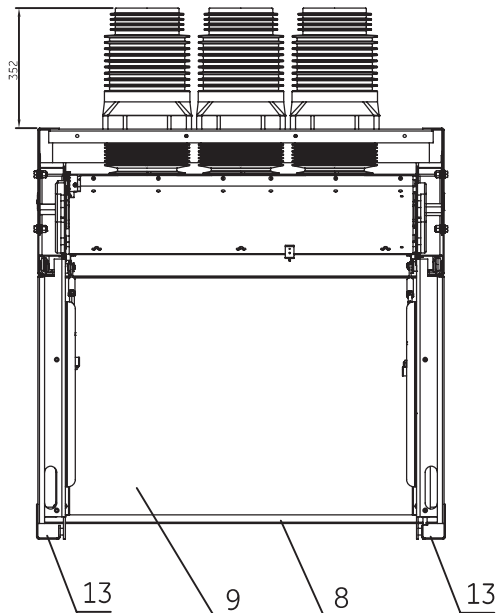
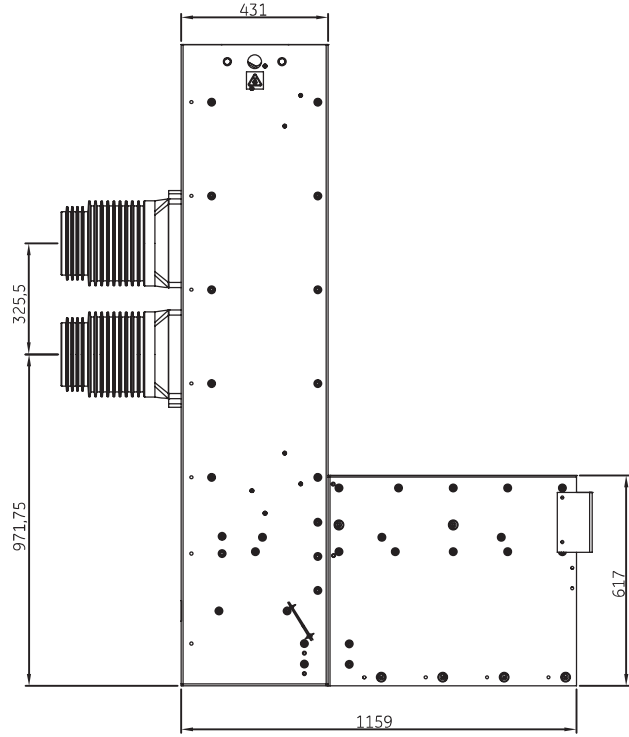
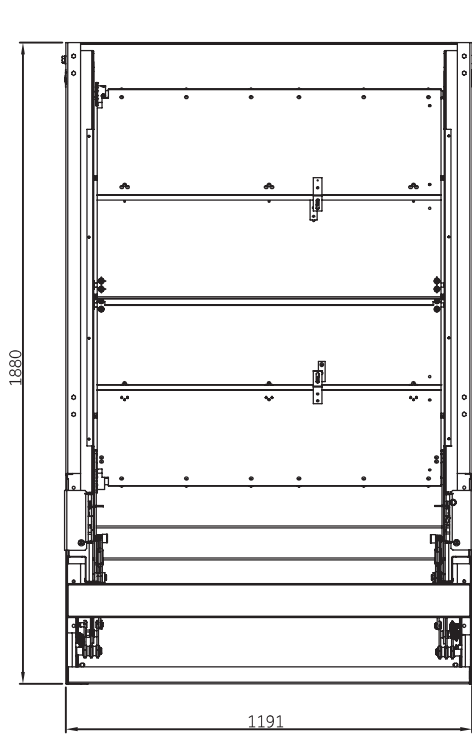

Note: remove support parts 8,9,13, before L-frame in use.

# Internal Wiring Diagram

## Withdrawable Installation for AC Control

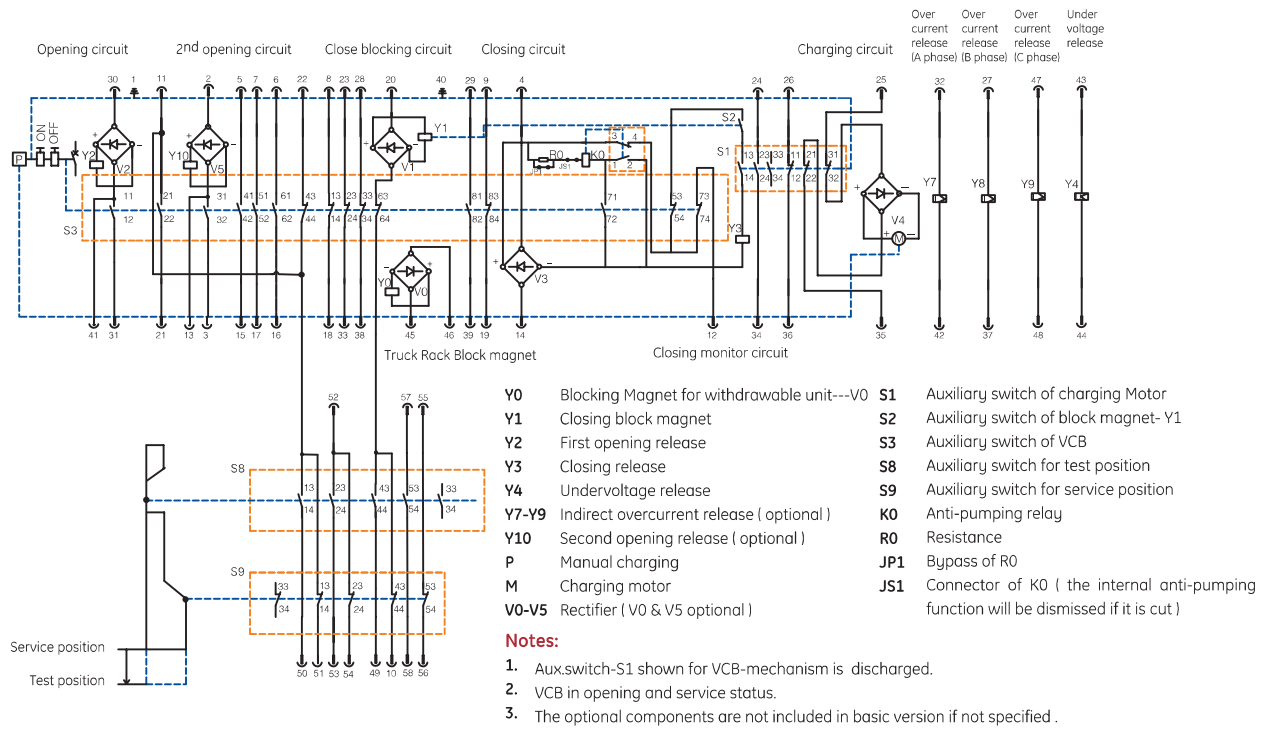

## Withdrawable Installation for DC Control

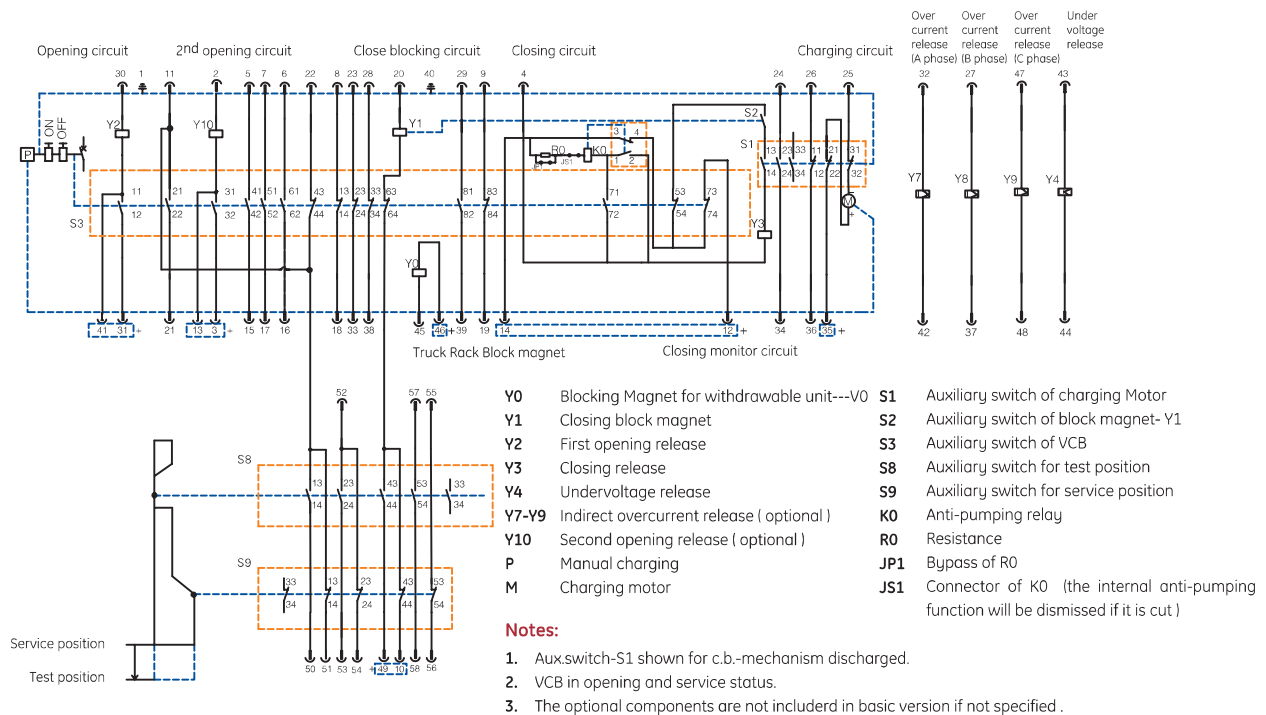

# Internal Wiring Diagram

## Fixed Installation for AC Control

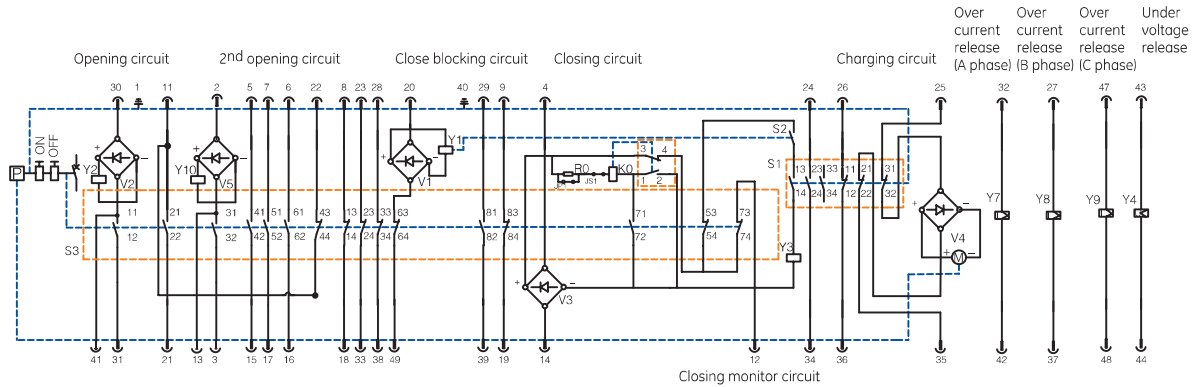

**Notes:**

1. Aux.switch-S1 shown for VCB-mechanism is discharged.
2. VCB in opening status.
3. The optional components are not included in basic version if not specified .
4. Auxiliary switch S2 should be bypassed when block magnet Y1 is not required.

- Y1** Closing block magnet
- Y2** First opening release
- Y3** Closing release
- Y4** Undervoltage release
- Y7-Y9** Indirect overcurrent release ( optional )
- Y10** Second opening release ( optional )
- P** Manual charging
- M** Charging motor
- V0-V5** Rectifier ( V0 & V5 optional )

- S1** Auxiliary switch of charging Motor
- S2** Auxiliary switch of block magnet- Y1
- S3** Auxiliary switch of VCB
- K0** Anti-pumping relay
- R0** Resistance
- JP1** Bypass of R0
- JS1** Connector of K0 ( the internal anti-pumping function will be dismissed if it is cut )

## Fixed Installation for DC Control

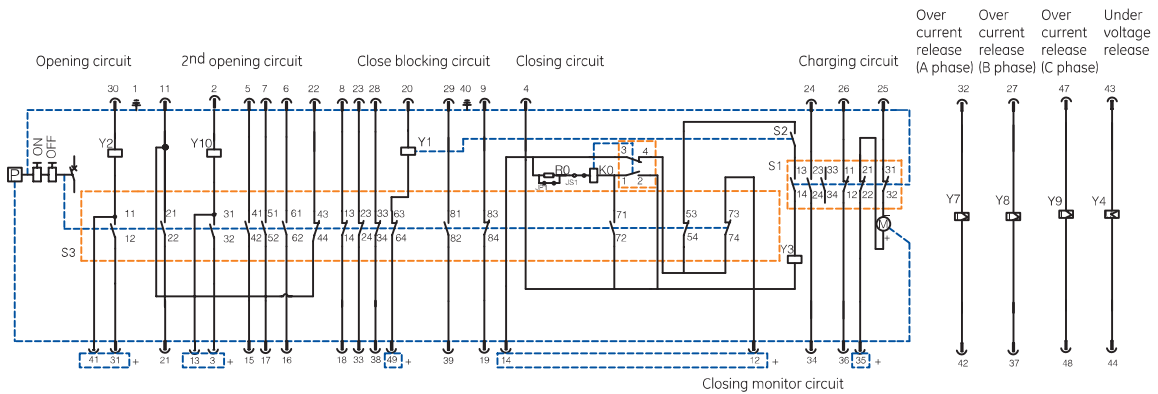

**Notes:**

1. Aux.switch-S1 shown for VCB-mechanism is discharged.
2. VCB in opening status.
3. The optional components are not included in basic version if not specified .
4. Auxiliary switch S2 should be bypassed when block magnet Y1 is not required.
5. The connect points in dashed are as should be connected with positive pole.

- Y1** Closing block magnet
- Y2** First opening release
- Y3** Closing release
- Y4** Undervoltage release
- Y7-Y9** Indirect overcurrent release ( optional )
- Y10** Second opening release ( optional )
- P** Manual charging
- M** Charging motor

- S1** Auxiliary switch of charging Motor
- S2** Auxiliary switch of block magnet- Y1
- S3** Auxiliary switch of VCB
- K0** Anti-pumping relay
- R0** Resistance
- JP1** Bypass of R0
- JS1** Connector of K0 ( the internal anti-pumping function will be dismissed if it is cut )

# Primary Scheme of SecoGear

## Primary Scheme of SecoGear

Scheme No.		1	2	3	4	5	6
Primary Scheme							
Dimension (WxDxH)		1200x2650x2400	1200x3300x2400	1200x3300x2400	1200x3300x2400	1200x2650x2400	1200x3300x2400
Main apparatus	SecoVac Vacuum Circuit Breaker	1	1	1	1	1	1
	Current Transformer	3	6	3	6	3	6
	Voltage Transformer						
	High Voltage Fuse						
	Earthing Switch						1
	Arrester	3	3				
Application		I.F	I.F	I.F(top)	I.F(top)	I.F	I.F

Scheme No.		7	8	9	10	11	12
Primary Scheme							
Dimension (WxDxH)		1200x2650x2400	1200x2650x2400	1200x3300x2400	1200x3300x2400	1200x3300x2400	1200x2650x2400
Main apparatus	SecoVac Vacuum Circuit Breaker	1	1	1	1	1	1
	Current Transformer	3	3	6	3	5	3+3
	Voltage Transformer				1		
	High Voltage Fuse				2		
	Earthing Switch	1	1	1	1		1
	Arrester		3		3		3
Application		I.F	I.F	I.F	I.F	I.F	I.F

## Primary Scheme of SecoGear

### Primary Scheme of SecoGear

Scheme No.	13	14	15	16	17	18	
Primary Scheme							
Dimension (WxDxH)	1200x2650x2400	1200x2650x2400	1200x3300x2400	1200x2650x2400	1200x2650x2400	1200x2650x2400	
Main apparatus	SecoVac Vacuum Circuit Breaker						
	Current Transformer						
	Voltage Transformer		3	3	3	2	3
	High Voltage Fuse		3	3	3	3	3
	Earthing Switch						
Arrester		3	3	3			
Application	D	F+P	P	P	P	P	

Scheme No.	19	20	21	
Primary Scheme				
Dimension (WxDxH)	1400x2650x2400	1200x2650x2400	1200x3300x2400	
Main apparatus	SecoVac Vacuum Circuit Breaker			
	Current Transformer			3
	Voltage Transformer			3
	High Voltage Fuse	3		3
	Earthing Switch			
	Arrester		3	
Application	T	S	M	

# Combinated Scheme

## Combinated Scheme

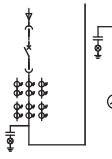
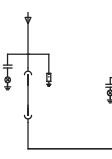
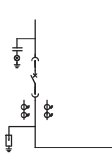
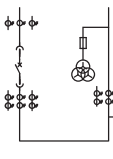
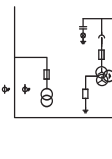
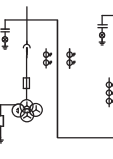
Scheme No.		1		2		3		4		5		6	
Primary Scheme													
Dimension (WxDxH)		1200 x3300 x2400	1200 x3300 x2400	1200 x3300 x2400	1200 x3300 x2400	1200 x2650 x2400	1200 x2650 x2400	1200 x2650 x2400	1200 x2650 x2400	1200 x2650 x2400	1200 x2650 x2400	1200 x2650 x2400	1200 x2650 x2400
Main apparatus	SecoVac Vacuum Circuit Breaker	1			1	1		1					
	Current Transformer	6			3	2		3	3	2		2	2
	Voltage Transformer		3						3	2	3	3	
	High Voltage Fuse		3						3	3	3	3	
	Earthing Switch												
	Arrester		3	3		3							
Application		I (top)+P		D+I		B		B+M		M		I+M	

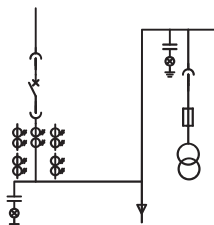
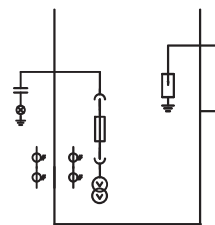
Scheme No.		7		8		
Primary Scheme						
Dimension (WxDxH)		1200 x3300 x2400		1200 x3300 x2400		
		1200 x2650 x2400		1200 x2650 x2400		
Main apparatus	SecoVac Vacuum Circuit Breaker	1				
	Current Transformer	5		2		
	Voltage Transformer		2		3	
	High Voltage Fuse		3		3	
	Earthing Switch				3	
	Arrester		3		3	
Application		F+M		P+M		

Meaning of code name in primary scheme:

I-Incoming F-outging D-Disconnecting B-Bustie R-Busbar rising M-Metering P-PT T-CPT S-Surge Arrester



# GEIS

GEIS Electric

Website: [www.geis.tech](http://www.geis.tech)

Hotline: +86 400-820-5234

This catalog may be subjected to revision without prior notice.  
Version No.: GENCSWAB26V1

