

# GEIS

## SecoMaC Load Interrupter Switchgear

GEIS Electrical Protection

Safer Smarter Greener



## About GEIS

GEIS was established in 2019 following the spin-off of several businesses and assets that ABB had acquired from GE on July 1, 2018, include 3 manufacturing centers, Warehousing & Trading business at FTZ, China Technology Center.

- Components: Full range of circuit breakers up to 40.5kV: Medium voltage vacuum circuit breakers, LV circuit breakers: ACB, MCCB, MCB, RCD, RCBO: Control components.
- Equipment: MV switchgear (Air insulation and Gas Insulation Technology), LV switchgear, switchboard.
- Medium voltage cast coil dry type transformer.
- Medium voltage ATS system (Paralleling Switchgear).

After the separation, all the above product lines were rebranded as AEG for selected markets and GEIS for global markets.



## Quality is Built-in

Vertical integrated Manufacturing Center

- Over 25 years of experience in localizing world-class products and manufacturing technologies, building strong expertise and a capable team.
- Consolidated most manufacturing processes under a single 60,000-square-meter facility in Shanghai.
- A strong R&D team dedicated to developing products that meet global standards and diverse applications.
- GEIS Thailand facility focuses on NEMA product lines.



---

**GEIS deliver complete range of products for the evolving electrification needs:**

---



**SecoVac** VCB



**M-PACT Plus** ACB



**Elfa** Series MCB/RCBO



**EV** Charger



**SecoGear** MV Switchgear



**RMU** Gas Insulated Switchgear



**WaveCast** Transformer



**MLS** LV Switchgear

# SecoMaC Load Interrupter Switchgear

## Catalogue

**A**

**Product Description**

**B**

**Structure**

**C**

**Configurations**

**D**

**Dimension**

**E**

**SecoMaC Load interrupter switch**

**F**

**GEIS RelGuard Interlocking System**

## Product Description

### Product Description

SecoMaC load interrupter switchgear (LISG) is a state-of-the-art electrical switchgear designed for medium-voltage power distribution systems. It integrates advanced technology, reliable performance, and compact structure, providing a safe, efficient, and intelligent solution for power supply and distribution in various industries.

SecoMaC LISG featuring the advanced interrupting technology of the SecoMaC Load Interrupter Switch (LIS), provides dependable, economical load switching and protection for medium voltage applications from 2.4kV through 15kV in 600A to 1200A load ratings.

### Applicable standards

SecoMaC LISG is designed, built and tested per the IEEE metal-enclosed switchgear standard and meet or exceed all applicable IEEE standards.

SecoMac LISG is available with enclosure protection ratings from NEMA 1 to NEMA 3R for various application.

### Applications

SecoMaC LISG is used mainly as a primary or secondary disconnect switch for transformers, but the variety of configurations in which SecoMaC LISG is available also make them useful for specific distribution needs. It can be used in a single circuit for on/off control of a transformer, duplex switching and selector switch applications. Typical applications are in oil and gas, pulp and paper, automotive, industrial processes, wastewater, petrochemical and utility-type industries.

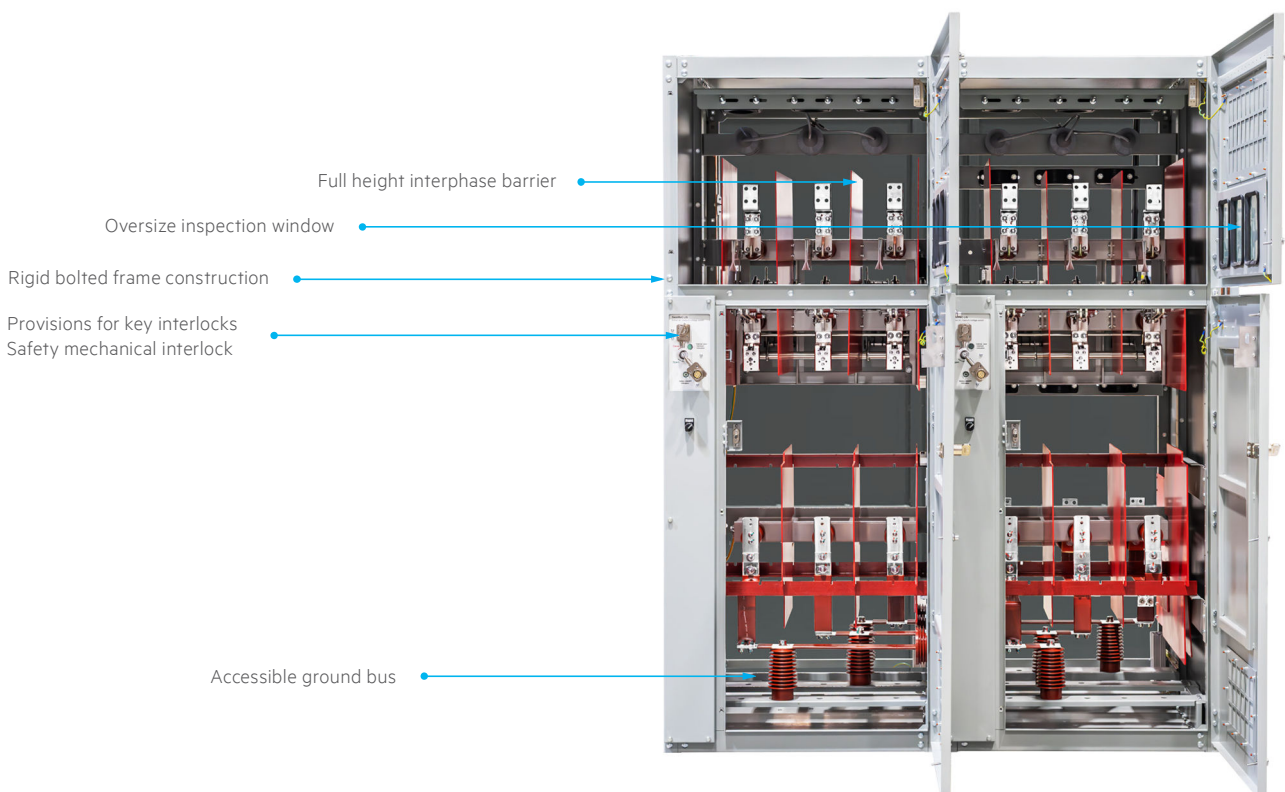

## Product Description

### Standards

<b>IEEE Std C37.20.3-2023</b>	IEEE Standard for Metal-Enclosed Interrupter Switchgear Rated above 1kV AC up to and Including 48.3kV AC
<b>IEEE Std C37.20.4-2013</b>	IEEE Standard for Indoor AC Switches (1kV-38kV) for Use in Metal-Enclosed Switchgear
<b>IEEE Std C37.100.1-2018</b>	IEEE Standard of Common Requirements for High Voltage Power Switchgear Rated Above 1000V
<b>ANSI C37.58-2020</b>	American National Standard for Switchgear - Indoor AC Medium-Voltage Switches for Use in Metal-Enclosed Switchgear- Conformance Test Procedures
<b>ANSI/NEMA 250-2020</b>	Enclosures for Electrical Equipment
<b>IEC 62271-1:2021</b>	High-voltage switchgear and controlgear Part 1: Common specifications for alternating current switchgear and controlgear
<b>IEC 62271-200: 2021</b>	High-voltage switchgear and controlgear -Part 200: AC metal-enclosed switchgear and controlgear for rated voltages above 1kV and up to and including 52kV



**Structure**

While accessing fuses, split door prevents access to the live side of the switch when the lower door is open. Oversized viewing window and switch position markers allow visual verification of switch position.

**Features**

- Full-length ground bus
- Polyester coat paint
- ANSI 61 paint color (gray)
- Oversized viewing window
- Full height interphase barriers
- 11-gauge doors, barriers and covers
- Generous cable termination area
- Permanent non-corrosive nameplate
- Switch padlock provisions
- Key interlock provisions
- Mechanical switch and door interlocking
- Safety Vertical barrier

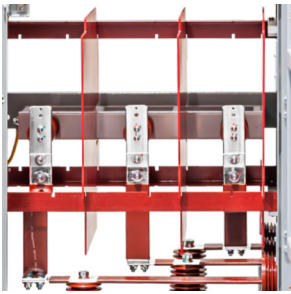

Full height interphase barriers are standard on all switches. Both current limiting and expulsion fuses are available.

**Accessories and features**

- Tin/Sliver-plated copper bus
- Insulated bus and bus boots over joints
- Weather and dust resistant
- Vertical barriers
- Rodent barriers
- Bottom closure plates
- Tamper resistant hardware
- Auxiliary switches (3NO-3NC)
- Thermostat
- Space heater
- Porcelain insulators
- Customer metering
- Surge arresters
- Mimic bus
- Space heater switch
- Ground studs
- Convenience light
- Duplex receptacle
- Top hat
- Run back bus

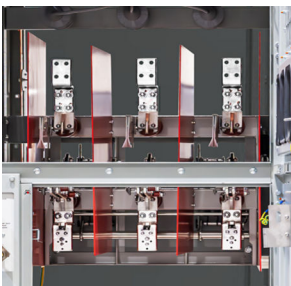

Vertical barriers between the switch mechanism and fuse compartment are a standard safety feature.

## Configurations

### Configurations

The complete line of SecoMac load interrupter switches can fulfill most distribution system requirements. They are available in a variety of configurations to meet specific distribution needs, including single switches, duplex switches, and line-ups. Customer metering and outdoor construction are also available.

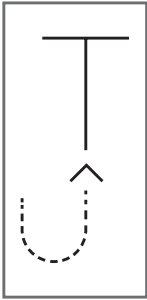

#### Incoming

The incoming section provides a cable entrance compartment.

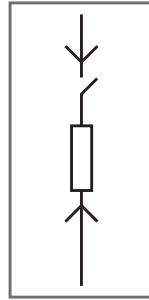

#### Single

The single switch section provides ON/OFF switching using one load break switch section, fused or non-fused as options, that can be configured as stand-alone (cable in/out) or with transition to incoming line side and bus bar connection for transformer load side.

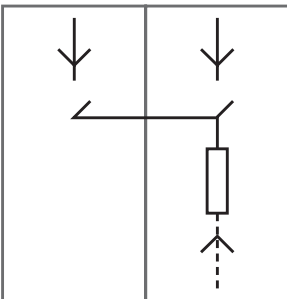

#### Duplex

The duplex switch provides on/off switching, using two load break switch sections (one fused, one unfused) connected to a common load. Mechanical interlocks (key interlocks) prevent both switches from being closed at the same time. The duplex switch functions as a switch between two power sources, a primary and auxiliary power source. The features of a duplex switch include:

- Two sections connected together
- One set of power fuses
- Four key interlocks included as standard

## Configurations

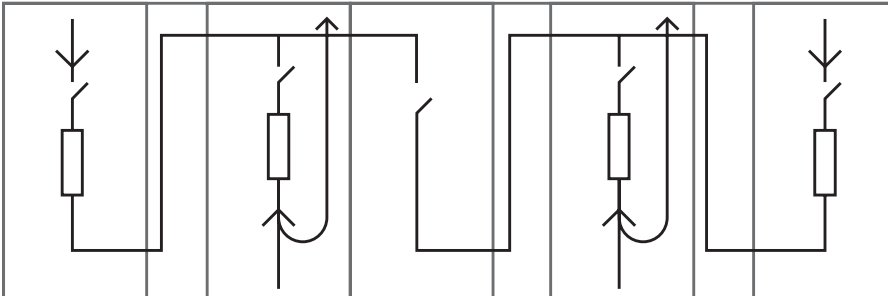

### Lineups

Features of a line-up include:

- 600, 1200A horizontal through bus
- Incoming line sections, main, tie (non-fused), branch switches, auxiliary (both bussed and unbussed), and transitions sections to other equipment are available
- Utility metering compartments are available as a factory-priced item
- All sections are front and rear aligned.

### Technical Parameters

Number	Project	Unit	Parameters
1	Rated maximum voltage ( $U_n$ )	kV	15
2	Rated power frequency ( $f_n$ )	Hz	50/60
3	Rated continuous current ( $I_n$ )	A	600, 1200
4	Rated insulation level ( $U_d, U_p$ )		
	1min Rated power-frequency withstand voltage ( $U_1$ )	Common value	36
		Across the isolating distance	40
	Rated lightning impulse withstand voltage ( $U_{pl}$ )	Common value	95
		Across the isolating distance	105
Rated power-frequency withstand voltage of auxiliary and control circuits	V	1500	
5	Rated peak withstand (momentary) current ( $I_p$ )	kA	65
6	Rated short-time withstand current ( $I_k$ )	kA	25
7	Rated load-switching current	A	600, 1200
8	Rated fault-making current	kA	40
9	Rated cable-charging switch current	A	14
10	Rated unloaded transformer switching current	A	21
11	Rated electrical operations	times	100
12	Rated mechanical operations	times	1000
13	Rated supply voltage of closing and opening devices and of auxiliary and control circuits ( $U_a$ )	V	AC120, AC240 DC125, DC250

# Dimension

## Indoor NEMA 1 Single Cabinet

### Dimension (mm)

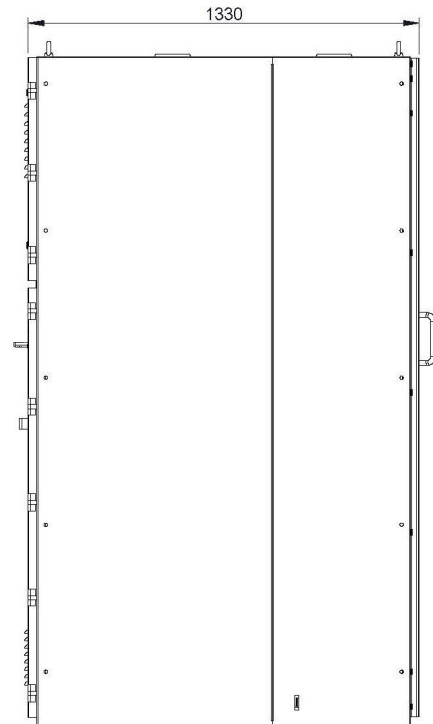
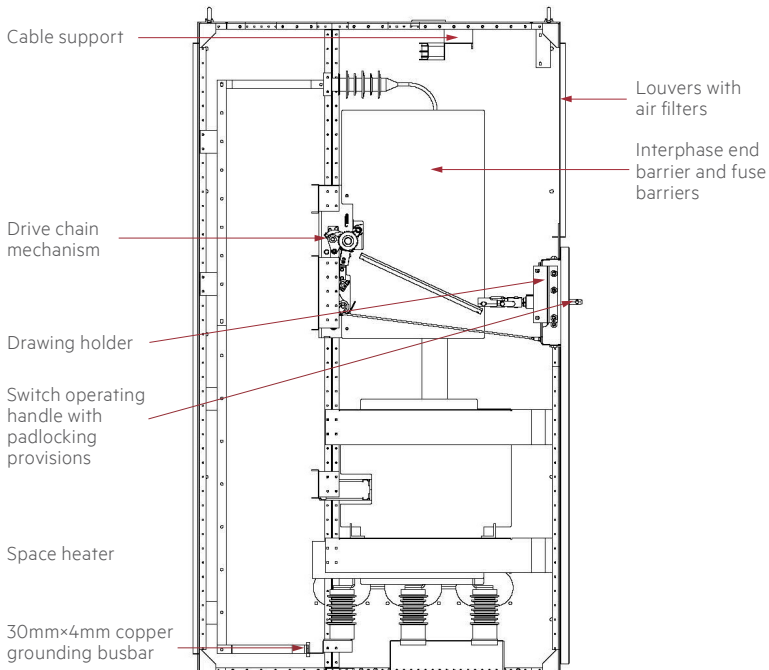
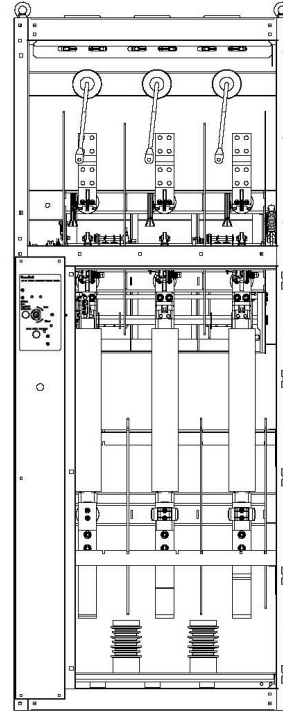
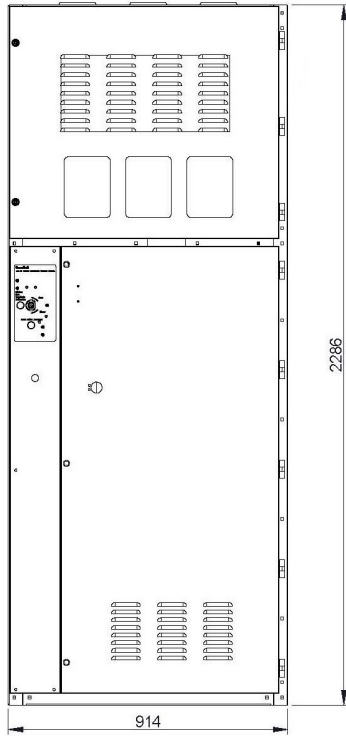

Indoor NEMA 1 Double Cabinet

Dimension (mm)

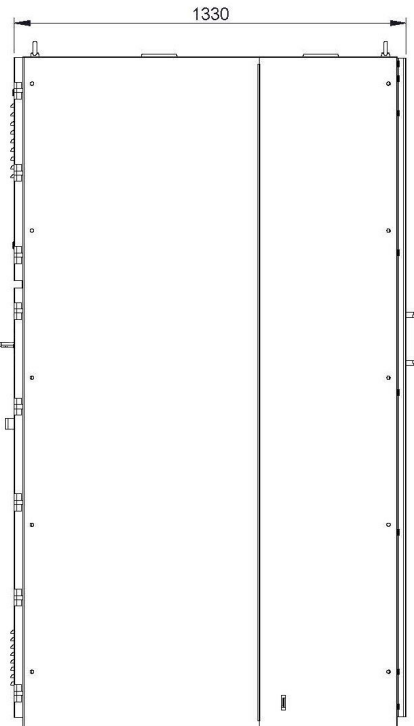
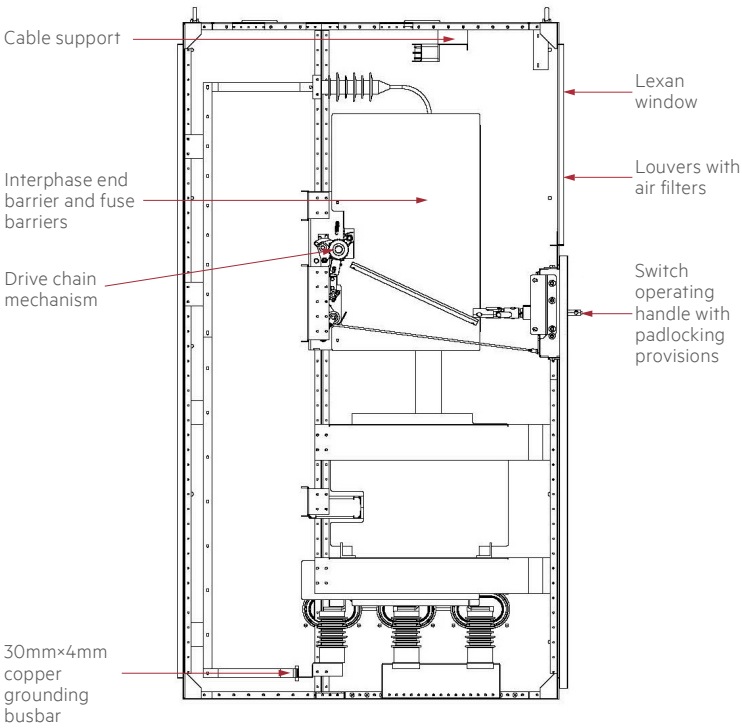
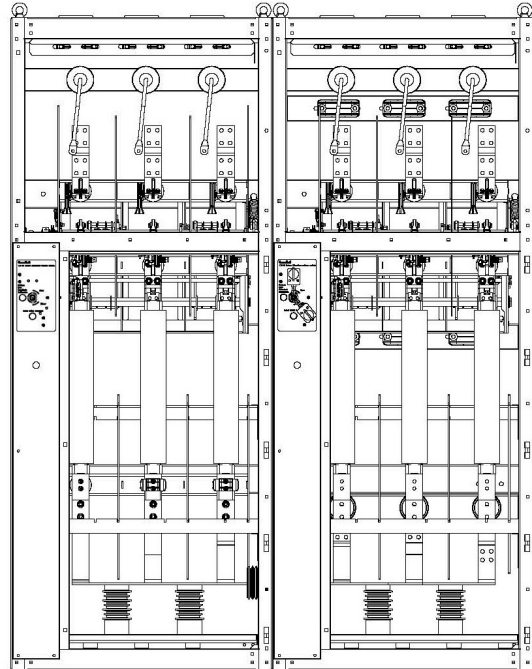
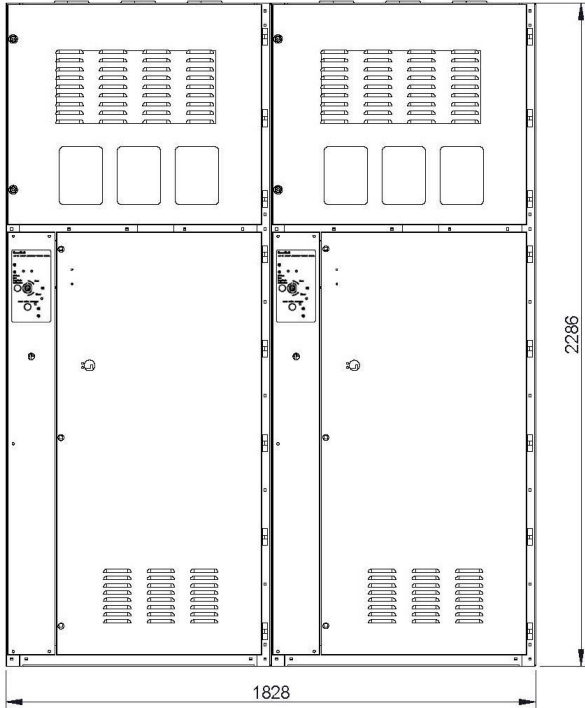

# Dimension

## Outdoor NEMA 3R Single Cabinet

### Dimension (mm)

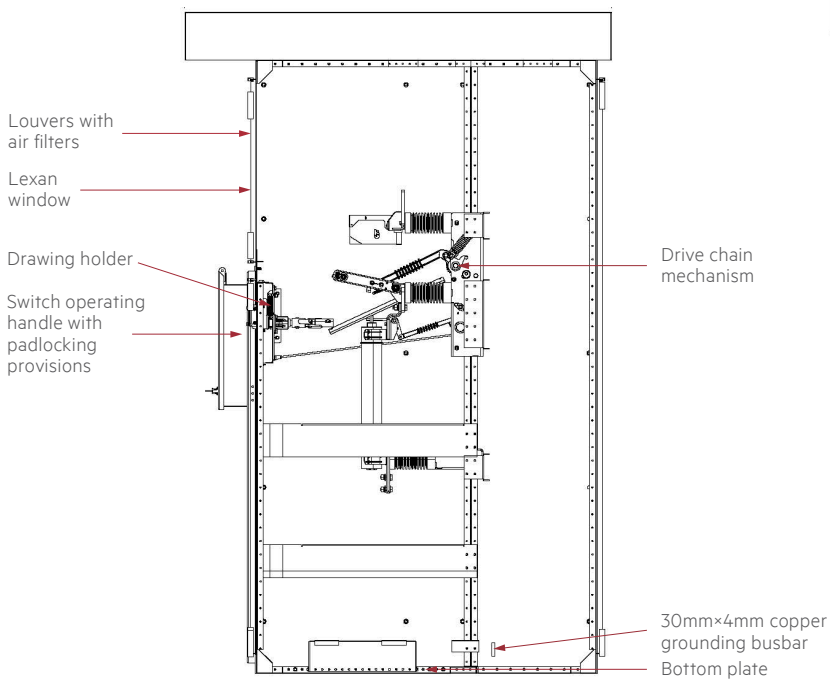
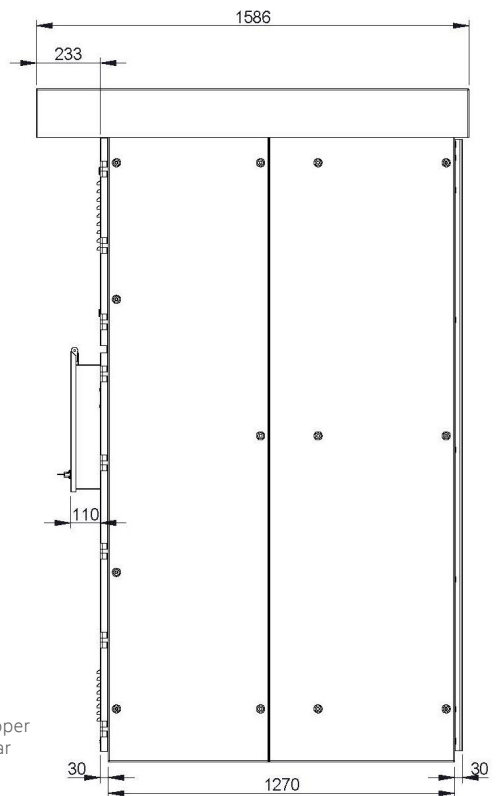
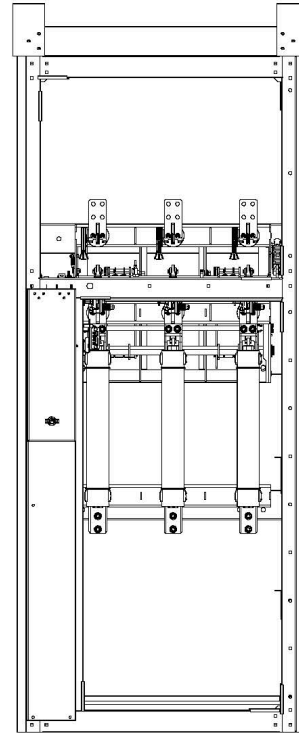
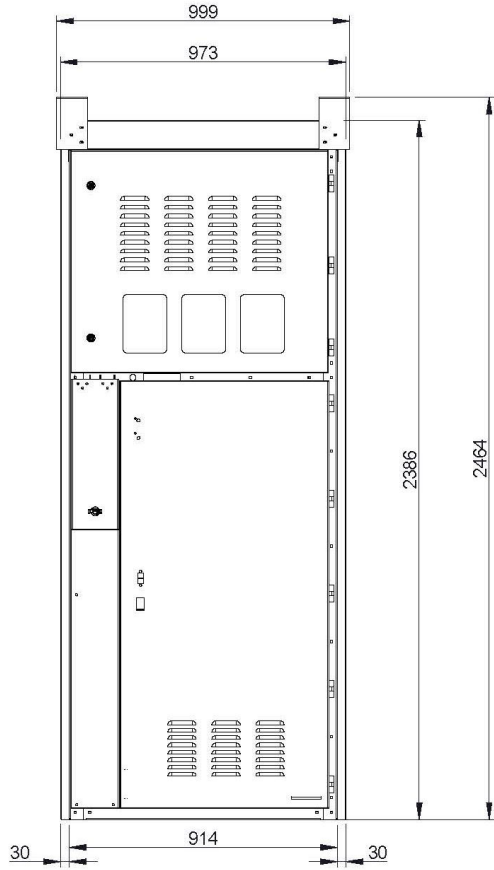

## SecoMaC Load interrupter switch

### SecoMaC Load interrupter switch

SecoMaC load interrupter switch is a general purpose, three-pole, loadbreak switch that offers switchgear owners and assemblers the benefit of an advanced interrupting technology and proven, dependable performance in a compact design.

#### Product highlights

- Puffer arc extinguishing system allows for a high number of operations without excessive wear
- Latches are not dependent on gravity, allowing for more flexibility in mounting arrangements
- Tight phase spacing without the requirement for interphase barriers on a majority of ratings
- Compact operating mechanisms available in stored energy or snap action varieties
- Compact motor operator provides local or remote control of SecoMaC LIS.

#### Applications

The main purpose of the SecoMaC LIS is to interrupt loads and open circuits under normal current. The SecoMaC switch has been used in the following applications:

- In transformer and motor protection with the use of fuses
- As a visual disconnect in mining applications
- In pad-mounted switch applications
- In various metal enclosed switchgear configurations such as switch over breaker, duplex, and maintenance bus scenarios

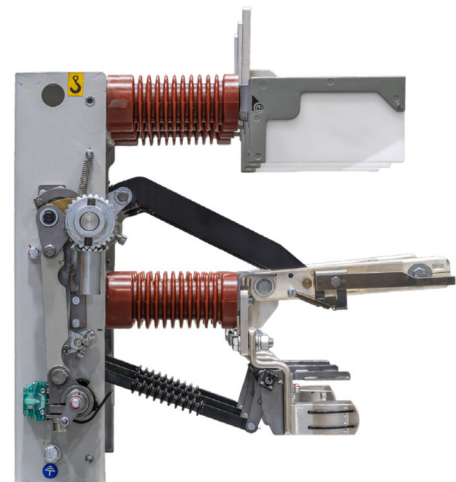
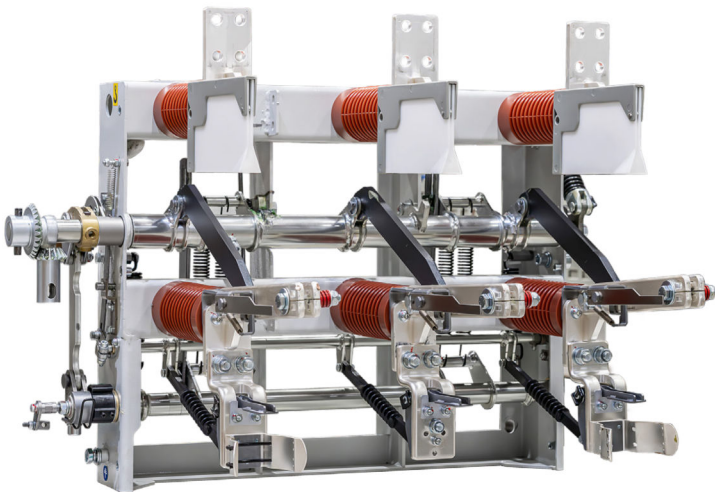

## SecoMaC Load interrupter switch

### Technical Parameters

Number	Project	Unit	Parameters
1	Rated maximum voltage ( $U_n$ )	kV	15
2	Rated power frequency ( $f_n$ )	Hz	50/60
3	Rated continuous current ( $I_n$ )	A	600, 1200
4	Rated insulation level ( $U_{\phi}$ , $U_p$ )		
	1min Rated power-frequency withstand voltage ( $U_d$ )	Common value	36
		Across the isolating distance	40
	Rated lightning impulse withstand voltage ( $U_p$ )	Common value	95
		Across the isolating distance	105
Rated power-frequency withstand voltage of auxiliary and control circuits	V	1500	
5	Rated peak withstand current ( $I_p$ )	kA	65
6	Rated short-time withstand current ( $I_k$ )	kA	25
7	Rated duration of short circuit ( $t_k$ )	s	2
8	Rated load-switching current	A	600, 1200
9	Rated fault-making current	kA	40
10	Rated cable-charging switch current	A	14
11	Rated unloaded transformer switching current	A	21
12	Rated electrical operations	times	100
13	Rated mechanical operations	times	1000
14	Rated supply voltage of closing and opening devices and of auxiliary and control circuits ( $U_a$ )	V	AC120, AC240 DC125, DC250

# SecoMaC Load interrupter switch

## SecoMaC Load interrupter switch

### Dimension (mm)

SecoMaC LIS (with Fuse)

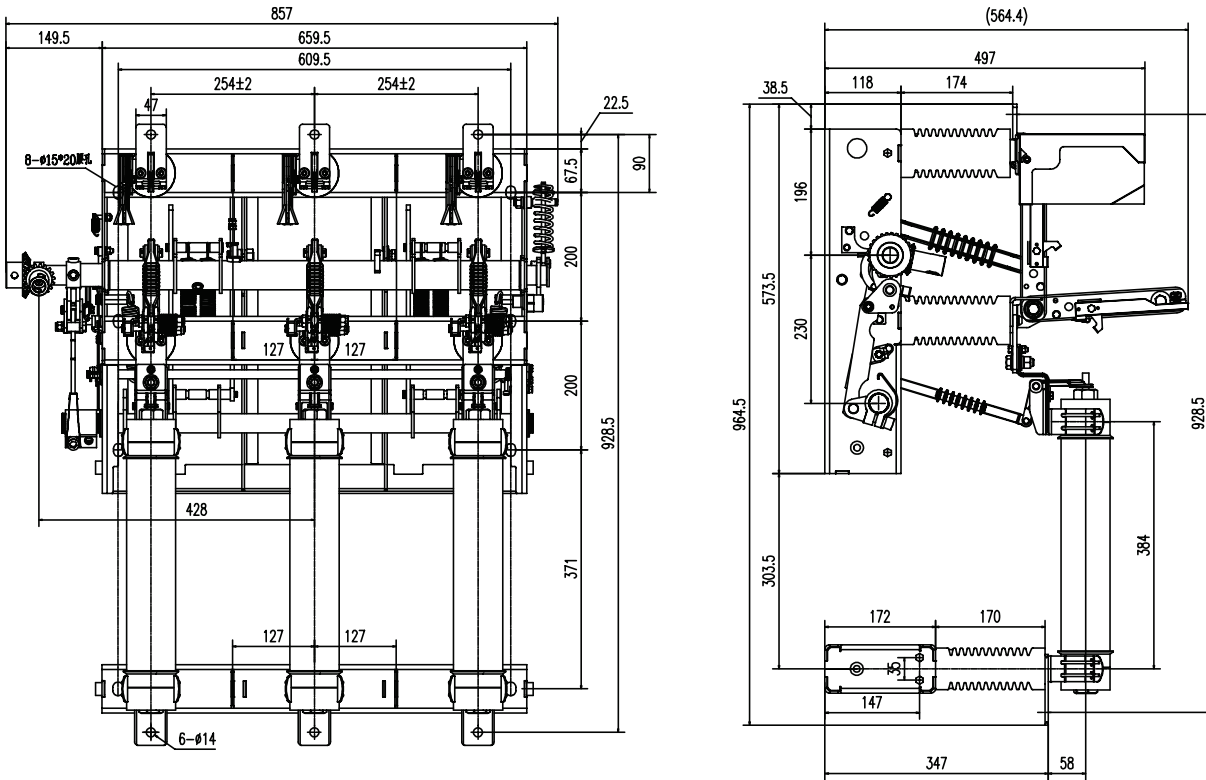

SecoMaC LIS

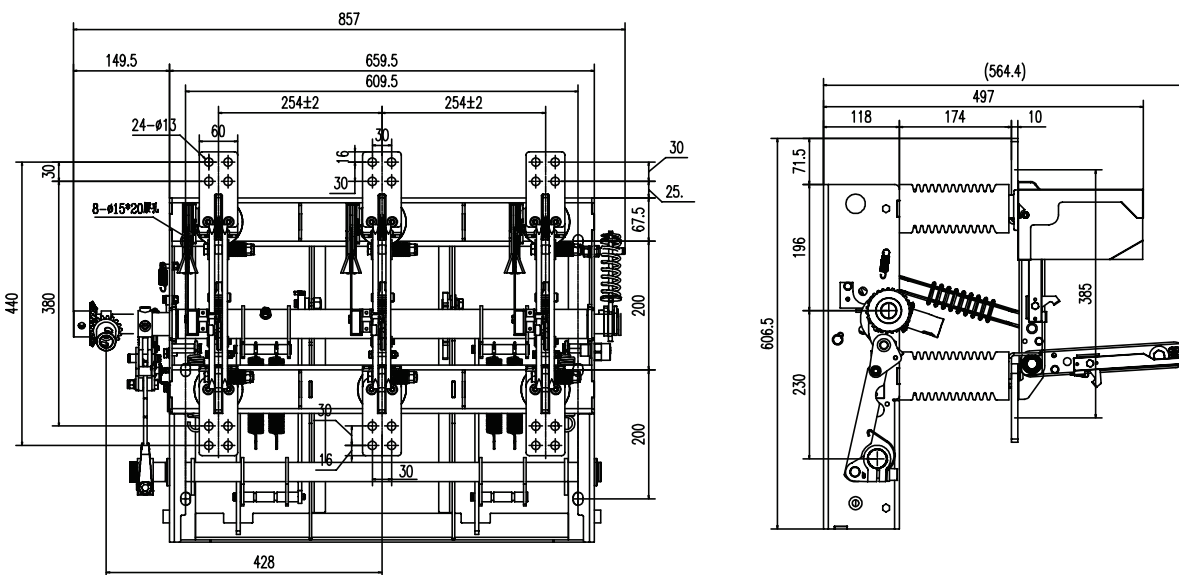

## GEIS RelGuard Interlocking System

### RelGuard Trapped Key Interlocking

#### Mechanical Safety by Design

Trapped Key Interlocking is a proven mechanical safety system that ensures safe operation of electrical equipment by enforcing a predefined operating sequence. Through the controlled release and transfer of uniquely coded keys, the system makes unsafe operations physically impossible.

GEIS RelGuard Interlocking System Built for Extremes. Proven for Safety. Compliant Worldwide.

Engineered to perform in the harshest conditions, the system delivers exceptional environmental resilience from  $-55^{\circ}\text{C}$  to  $+85^{\circ}\text{C}$ , withstanding high humidity, salt mist, dust, vibration, and solar radiation in full compliance with international standards.

- Extreme Environment Ready. Safety Engineered.
- Reliability Without Compromise—From Arctic Cold to Desert Heat.
- Engineered to Withstand. Designed to Protect.
- Certified Performance for the World's Harshest Conditions.



#### Technical Specifications

##### Environmental performance

Low air temperature	$-55^{\circ}\text{C}$ , Compliant with the IEC 60068-2-1 standard
Atmospheric temperature at high altitude	$85^{\circ}\text{C}$ , Compliant with the IEC 60068-2-2 standard
Temperature change rate	$-55^{\circ}\text{C} \sim 85^{\circ}\text{C}$ , Compliant with the IEC 60068-2-14 standard
High temperature and high humidity	$25^{\circ}\text{C} \sim 85^{\circ}\text{C}$ , 99% relative humidity, Compliant with the IEC 60068-2-30 standard
Salt spray	720h, Compliant with the IEC 60068-2-11 standard
Electrochemical compatibility of materials	Compliant with the MIL-STD-889D

##### Mechanical properties

Impact	IK08
Vibration	Compliant with the IEC 60068-2-6, IEC 61373 standard
Low pressure	Compliant with the IEC 60068-2-13 standard
Solar radiation	Compliant with the IEC 60068-2-5 standard
Dust and dirt	Compliant with the IEC 60068-2-68 standard
Mechanical safety and reliability	B10d, 1000000 cycles, Compliant with the ISO 13849-1 standard
PL Level	PLd
Protection level	IP40
Mechanical tolerance	$\geq 60\text{daN}$

##### Environmental protection and chemical compliance

Compliant with the requirements for restricted substances as stipulated in RoHS, REACH, TSCA, PFAS, SCIP, CMRT, EMRT and Prop 65

RelGuard converts safety procedures into physical safeguards—delivering confidence, consistency, and protection for both personnel and equipment.







# GEIS

GEIS Electric  
Website: [www.geis.tech](http://www.geis.tech)  
Hotline: +86 400-820-5234

This catalog may be subjected to revision without prior notice.  
Version No.: GENCSWAC26V1

