

GEIS

SecoVac

VB2 Plus G-15 Generator Circuit Breaker

GEIS Electrical Protection

Safer Smarter Greener



About GEIS

GEIS was established in 2019 following the spin-off of several businesses and assets that ABB had acquired from GE on July 1, 2018, including 3 manufacturing centers, Warehousing & Trading business at FTZ, China Technology Center.

- Components: Full range of circuit breakers up to 40.5kV: Medium voltage vacuum circuit breakers, LV circuit breakers: ACB, MCCB, MCB, RCD, RCBO: Control components.
- Equipment: MV switchgear (Air insulation and Gas Insulation Technology), LV switchgear, switchboard.
- Medium voltage distribution transformer.
- Medium voltage ATS system (Paralleling Switchgear).

After the separation, all the above product lines were rebranded as AEG for selected markets and GEIS for global markets. Moreover, GEIS has expanded its technological portfolio to include medium-voltage controls such as VFDs and soft starters, as well as ATS systems and EV chargers.



Quality is Built-in

Where Technology Meets Manufacturing Excellence for Customers

- Since 2000, we have been specializing in localizing world-class products and manufacturing technologies, developing strong expertise and a highly capable team.
- Vertical integrated Shanghai Manufacturing Center brought key manufacturing processes into a 75,000 m² facility, enabling high-quality, high-efficiency production and fostering innovation. A dedicated R&D team committed to developing products that meet global standards and serve diverse applications.
- Global expansion: GEIS's first Thailand facility makes it easier to serve customers worldwide.



GEIS deliver complete range of products for the evolving electrification needs:



SecoVac VCB



M-PACT Plus ACB



Elfa Series MCB/RCBO



SolidDrive MV VFD



SecoGear MV Switchgear



RMU Gas Insulated Switchgear



WaveCast Transformer



MLS LV Switchgear

VB2 Plus G-15 Generator Circuit Breaker

Catalogue

A

Product Description

- A.1 Introduction
- A.1 Service Conditions/ Storage
 - A.1 Normal service conditions
 - A.2 Special service conditions
- A.2 Storage

B

Technical Data

- B.1 Technical Data

C

Overall Dimensions

- C.1 Overall Dimensions

D

Internal Wiring Diagram

- D.1 Internal Wiring Diagram

E

Structure

- E.1 Overview
 - E.1 Primary circuit
 - E.2 Operating mechanism

F

Order Sheet

- F.1 Order Sheet

Product Description

Product Overview

The SecoVac VB2 Plus G circuit breaker designed for three-phases AC up to 15kV rated voltage, and can be used for switching and protecting generators in industrial, mining and power plants applications. The product conforms to IEC/IEEE 62271-37-013. The breaker can be installed in the switchgear in fixed or withdrawable arrangements. It is the optimum choice for the control and protection of MV generators.



Service Conditions/ Storage

Normal Service Conditions

- Unless otherwise specified, SecoVac VB2 Plus G circuit breakers, including the operating devices and the auxiliary equipment which form an integral part of them, are intended to be used in accordance within their rated operating parameters and normal service conditions listed as follows.
- The ambient air temperature does not exceed 40°C and its average value, measured over a period of 24h, does not exceed 35°C. The minimum operating ambient air temperature is -15°C. (storage and transportation is allowed at -30°C).
- The altitude does not exceed 1000m
- The ambient air is not significantly polluted by dust, smoke, corrosive and/or flammable gases, vapours or salt.
- The conditions of humidity are as follows:
 - The average value of relative humidity, measured over a period of 24h, does not exceed 95%.
 - The average value of water vapour pressure, measured over a period of 24h, does not exceed 2.2kPa.
 - The average value of the relative humidity, measured over a period of one month, does not exceed 90%.
 - The average value of water vapour pressure, measured over a period of one month, does not exceed 1.8kPa.
- Seismic intensity is not more than UBC Zone 4.

Product Description

Service Conditions/ Storage

Special service conditions

If the actual service conditions differ from the normal service conditions, the circuit breaker and associating devices and auxiliary equipment shall be designed and made to comply with any special service conditions. This must be discussed with GEIS in advance.

Normally, the following special service conditions will be encountered:

- At sites with altitude above 1000m, the effects of the reduction in dielectric strength of the air must be taken into account. GEIS can supply circuit breakers which can be applied in areas less than 3000m above sea level. At this time, the insulation level in the switchgear should be taken into account and must be discussed with GEIS in advance.
- The ambient temperature is above 40°C. The rated current of circuit breaker shall be derated or fans shall be installed for heat dissipation. Please confirm with GEIS in advance.

Attention

- When circuit breakers are operated in areas with high humidity and/or major rapid temperature fluctuations, there is a risk of condensation, thus
 - Put the circuit breaker into operation as soon as possible after the package is dismantled
 - Turn on the anti condensation heater into service as soon as possible after the switchgear is installed

Storage

- The product should be subject to normal transportation conditions and shall be protected fully from rain and water spray.
- Do not store product other than as indicated on packaging. Damage is possible if stored on side/back or top.
- If immediate installation is not possible, please maintain original packaging or otherwise similarly protect the product. After inspection and stored, the circuit breaker should be switched off and the spring mechanism should be discharged.
- The product shall be stored in dry and ventilated indoor place free of dust severe contamination, chemical corrosion and vibrations. The climate condition conforms to related specifications in IEC/IEEE 62271-37-013 and adequate air circulation shall be maintained. The store room temperature shall not be lower than -30°C. Check periodically to avoid condensation inside breaker.

Technical Data

Electrical Parameter

Rated short-circuit breaking current	kA	31.5		40		50	
Rated Voltage	kV	15		15		15	
Rated Current	A	2500/3150/4000*		2500/3150/4000*		2500/3150/4000*/5000*	
Rated Frequency	Hz	50/60		50/60		50/60	
Rated power Freq withstand voltage (1 min)	kV	38		38		38	
Rated lightning impulse withstand voltage	kVp	95		95		95	
Operation sequence		CO – 30min - CO		CO – 30min - CO		CO – 30min - CO	
Generator Circuit Class		G2		G2		G2	
Location of fault (refer below schematic diagram)		'a' 'System supplied fault	'b' 'Generator supplied fault	'a' 'System supplied fault	'b' 'Generator supplied fault	'a' 'System supplied fault	'b' 'Generator supplied fault
Rated short-circuit breaking current	kA	31.5	15.8	40	25	50	25
Rated short-circuit making current: Ipeak	kAp	86.5	34.1	110	54	137	54
Interrupting Time	ms	50		50		50	
Minimum Opening Time	ms	24.3		24.3		24.3	
Degree of Asymmetry	%	75	130	75	130	75	130
Asymmetry interrupting capability	kAp	46	34.1	58.4	36.5	73	36.5
Close and Latch Capability	kAp	86.3		110		110	
Rated short time withstand current	kA	31.5	N/A	40	N/A	50	N/A
Rated duration time for short-circuit	s	3	N/A	3	N/A	3	N/A
Rate of Rise of Recovery Voltage (RRRV)	kV/μs	3.5	1.6	3.5	1.6	3.5	1.6
Peak Recovery Voltage	kV	27	27	27	27	27	27
Out-of-Phase Current Switching							
Duty Voltage	kV	21.2	N/A	21.2	N/A	21.2	N/A
Breaking Current	kA	15.8	N/A	20	N/A	25	N/A
Max. Making Current (V~0)	kAp	31.5	N/A	40	N/A	40	N/A
Rate of Rise of Recovery Voltage (RRRV)	kV/μs	3.3	N/A	3.3	N/A	3.3	N/A
Peak Recovery Voltage	kV	39	N/A	39	N/A	39	N/A
Mechanical life operations	Number	10000		10000		10000	
Center distance between phase	mm	275		275		275	

*4000A/5000A are VCB with force cooling, detail please connect with GEIS.

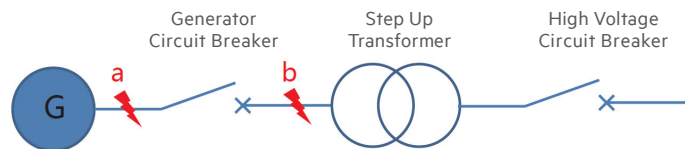

Control Circuit Data

Rated Voltage(V)	Resistance Value (Ω)	Rated Current (A)	Inrush Current (A)	Maximum Power (W)
DC48	6	8	48	384
DC125/AC120	50	2.5	14.9	313
DC250/AC240	170	1.5	8.8	375

Rated Voltage(V)	Normal Operation Voltage Range (V)	Charging Time at Rated Voltage (s)	Input Power (W)
DC48	36-56	<15s	100
DC125	90-140	<15s	100
DC250	180-280	<15s	100
AC120	104-127	<15s	100
AC240	208-254	<15s	100

Overall Dimensions

Withdrawable type

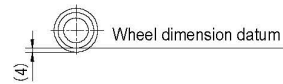
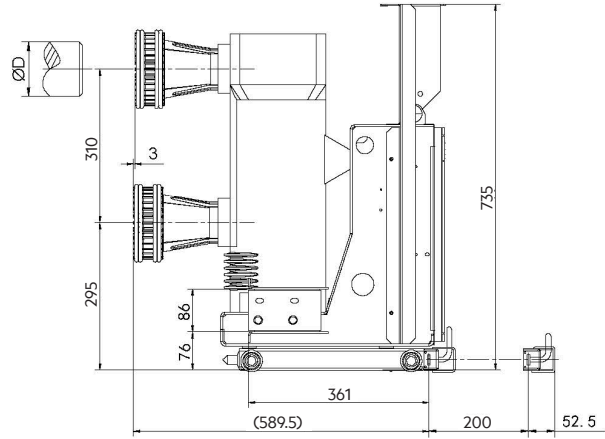
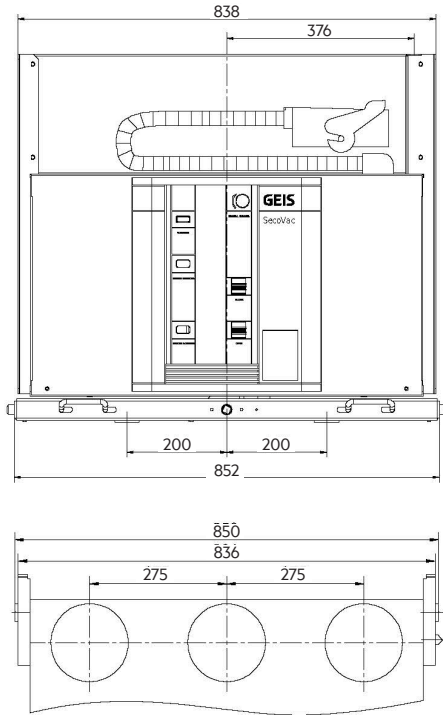

Specifications	D
2500A/31.5~50kA	Ø109
3150A/31.5~50kA	Ø109
4000A/31.5~50kA	Ø109
5000A/50kA	Ø109

Fixed type

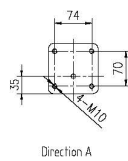
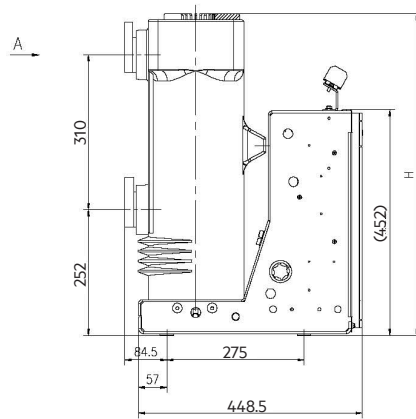
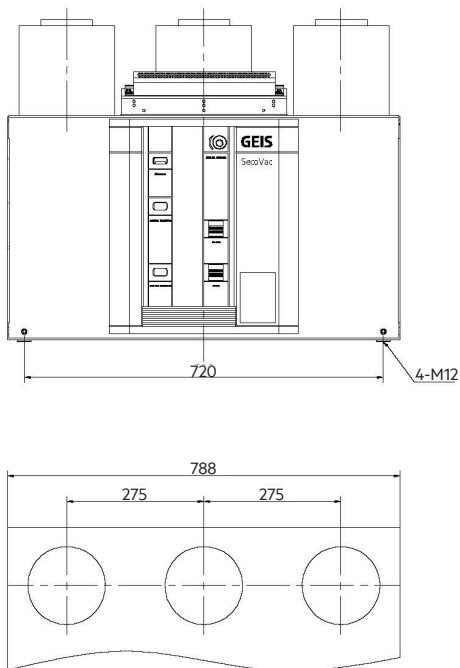

Specifications	H
2500A/31.5~50kA	632
3150A/31.5~50kA	632
4000A/31.5~50kA	632
5000A/50kA	644

Internal Wiring Diagram

Withdrawable type

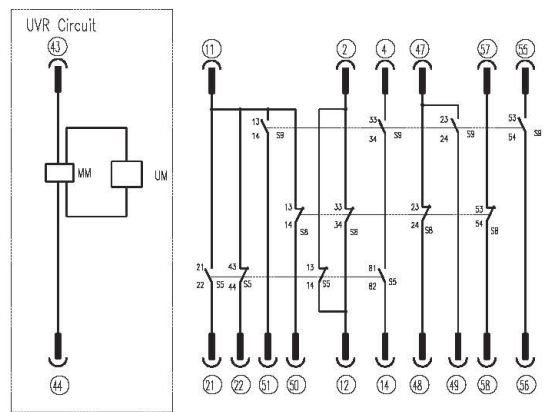
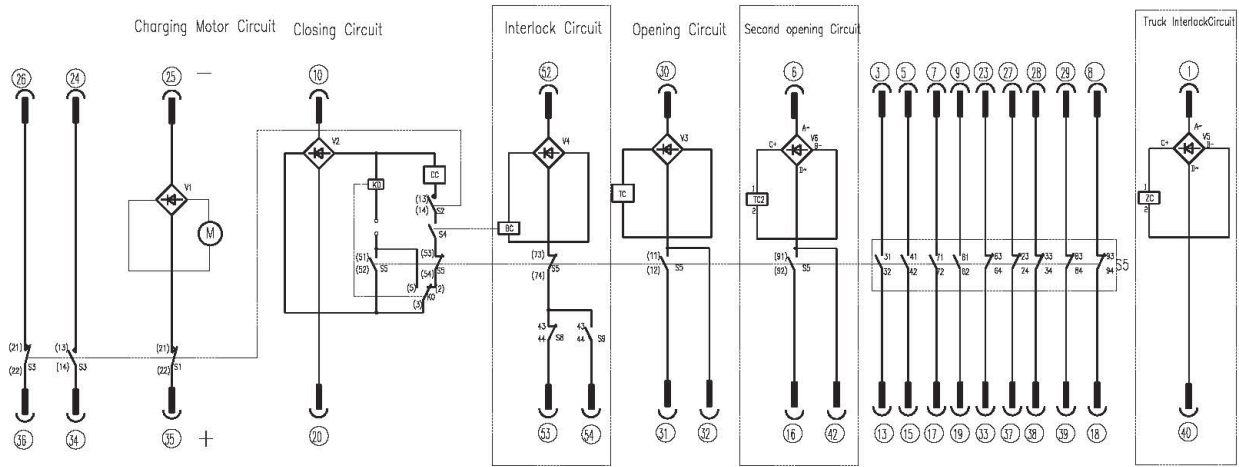

- Note:
1. This wiring diagram describes that a breaker is uncharged and is in an opening state, and the handcart is in the testing position.
 2. The dotted box for optional feature
 3. If the control voltage is DC24V, DC30V, no Rectifier, so note charging motor circuit +,-

S9: Limit switch (working position)	CC: Closing coil	KO: Anti-jumping relay (optional)
S8: Limit switch (testing position)	TC: Opening coil	BC: Electromagnet far locking (optional)
S4: Electromagnet for lacking's auxiliary switch	M: Energy storing motor	UM,MM: UVR Coil (optional)
S5: Auxiliary switch	BC: Interlock coil (optional)	TC2: Second Opening coil (optional)
S1~S3: Energy storing travel switch	V1~V6: Rectifier	

Internal Wiring Diagram

Fixed

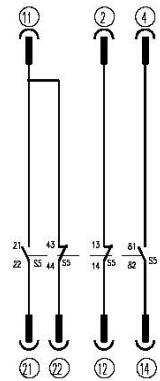
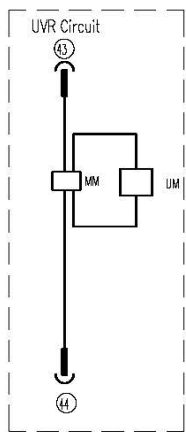
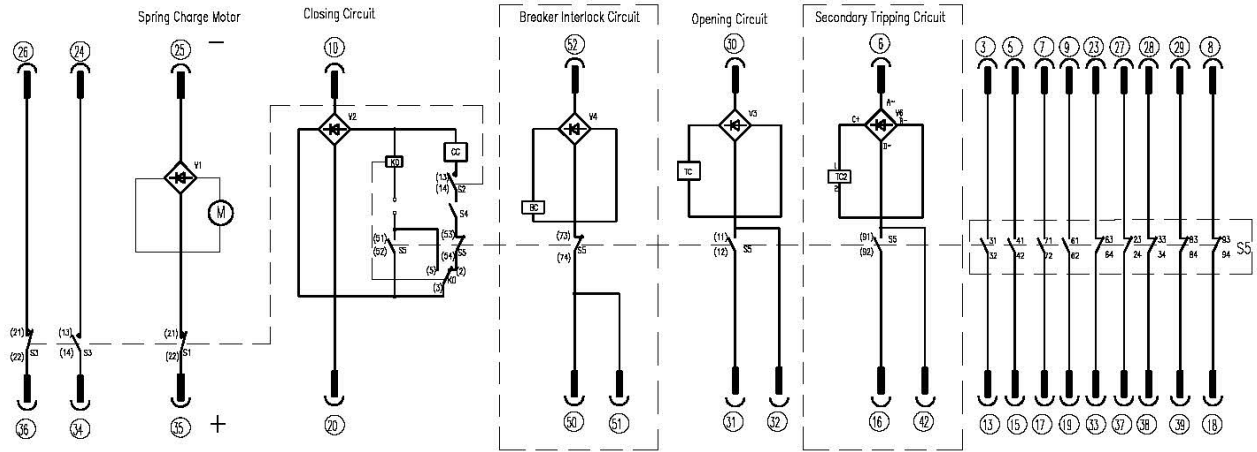

Note:

1. This wiring diagram describes that a breaker is uncharged and is in an opening state.
2. The dotted box for optional feature
3. If the control voltage is DC24V,DC30V, no Rectifier, so notecharging motor circuit +,-

S4: Electromagnet for locking's auxiliary switch	CC: Closing coil	K0: Anti-jumping relay (optional)
S5: Auxiliary switch	TC: Trip coil	UM,MM: UVR Coil(optional)
S1-S3: Energy storing travel switch	M: Energy storing motor	
V1-V6: Rectifier	TC2: Opening coil (optional)	

Product Overview

The VB2 Plus G circuit breaker uses a vacuum interrupter for the making and breaking of an electric power circuit. The movable primary cluster contacts on the breaker are connected to fixed primary contacts in the switchgear and a secondary disconnectable plug connects with the secondary socket of the switchgear. The operating mechanism is equipped with a compact spring charging mechanism. The mechanism adopts a modular design method and some parts have multiple functions.



Figure 1 Primary circuit

- 1. Upper arm
- 2. Embedded poles
- 3. Lower arm
- 4. Cluster

Primary circuit

The primary circuit is made up of cluster upper arms, lower arms and embedded poles (figure 1). The vacuum interrupters and main contact parts are embedded in epoxy resin using APG process, which ensure the vacuum interrupters are protected from the ambient influence and mechanical damage.

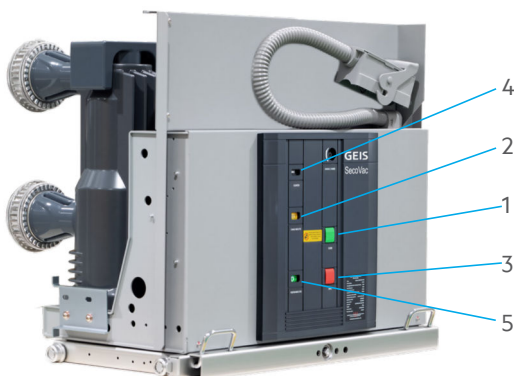

Figure 2 Front panel of the circuit breaker





- 1. Opening button
- 2. Status indicator for charging
- 3. Closing button
- 4. Counter
- 5. Indicator for open or close

Structure

Operating mechanism

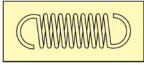
The spring operating mechanism consists of a single module. The operating mechanism is equipped with manual charging device which uses the charging handle and an electric charging device which charges the spring via a motor. The mechanism has a reclose function.

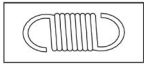
On the front panel of the circuit breaker, there are Open/Close, Charged/Discharged indicators and the manual operating handle. The operator can operate the breaker locally through manual push buttons or remotely via the closing and opening coils, the status of the circuit breaker can be observed on the front panel (figure 2).

Energy charged status indicator		Closing-opening status indicator		Manual closing & opening buttons	
	The spring is charged		The circuit breaker is closed		Manual closing button
	The spring is discharged		The circuit breaker is opened		Manual opening button

Ordering Check List

VB2 plus G-15 Generator Circuit Breaker (MVAE25V1)

Project _____ **Product** _____

Order Quantity _____

Rated voltage: 15kV **Operating Mechanism:** Spring **Structure:** Withdrawable Fixed

Pole type	<input checked="" type="checkbox"/> Embedded Pole
Phase Distance	<input checked="" type="checkbox"/> 275mm
Rated current	<input type="checkbox"/> 2500A <input type="checkbox"/> 3150A <input type="checkbox"/> 4000A <input type="checkbox"/> 5000A <input type="checkbox"/> others
Breaking Current	<input type="checkbox"/> 31.5kA <input type="checkbox"/> 40kA <input type="checkbox"/> 50kA
Earthing Mode	<input type="checkbox"/> Earthing with copper bar at the bottom of truck <input type="checkbox"/> Earthing with connector on the sides of truck
Open&Close Coil	<input type="checkbox"/> DC110V <input type="checkbox"/> DC220V <input type="checkbox"/> AC110V <input type="checkbox"/> AC220V
Charging Motor	<input type="checkbox"/> DC110V <input type="checkbox"/> DC220V <input type="checkbox"/> AC110V <input type="checkbox"/> AC220V
Secondary Wiring	<input type="checkbox"/> Withdrawable Method (64 Pin) <input type="checkbox"/> Fixed Method <input type="checkbox"/> Withdrawable Method (58 Pin) <input type="checkbox"/> Other Method
Other **	Close Interlock <input type="checkbox"/> DC110V <input type="checkbox"/> DC220V <input type="checkbox"/> AC110V <input type="checkbox"/> AC220V
	Truck Interlock <input type="checkbox"/> DC110V <input type="checkbox"/> DC220V <input type="checkbox"/> AC110V <input type="checkbox"/> AC220V
	Anti Pump <input type="checkbox"/> YES
Over Current Release *	<input type="checkbox"/> Without over current release <input type="checkbox"/> 1 over current release <input type="checkbox"/> 2 over current release <input type="checkbox"/> 3 over current release
Standard Accessory *	<input type="checkbox"/> Energy-stroing handle (2 pcs for each 5 breakers) <input type="checkbox"/> Rocking handle of chassis (2 pcs for each 5 breakers)

Special Request: _____

Signature of buyer _____ **Date** _____ / _____ / _____

*It will have additional cost if not a standard product (except anti-pump relay).

GEIS

GEIS Electric

Website: www.geis.tech

Hotline: +86 400-820-5234

This catalog may be subjected to revision without prior notice.
Version No.: GENCMVAE26V1

