

# GEIS

## SecoVac

### 3.3kV-27kV Embedded Pole Vacuum Circuit Breaker

GEIS Electrical Protection

Safer Smarter Greener



## About GEIS

GEIS was established in 2019 following the spin-off of several businesses and assets that ABB had acquired from GE on July 1, 2018, including 3 manufacturing centers, Warehousing & Trading business at FTZ, China Technology Center.

- Components: Full range of circuit breakers up to 40.5kV: Medium voltage vacuum circuit breakers, LV circuit breakers: ACB, MCCB, MCB, RCD, RCBO: Control components.
- Equipment: MV switchgear (Air insulation and Gas Insulation Technology), LV switchgear, switchboard.
- Medium voltage distribution transformer.
- Medium voltage ATS system (Paralleling Switchgear).

After the separation, all the above product lines were rebranded as AEG for selected markets and GEIS for global markets. Moreover, GEIS has expanded its technological portfolio to include medium-voltage controls such as VFDs and soft starters, as well as ATS systems and EV chargers.



# Quality is Built-in

## Where Technology Meets Manufacturing Excellence for Customers

- Since 2000, we have been specializing in localizing world-class products and manufacturing technologies, developing strong expertise and a highly capable team.
- Vertical integrated Shanghai Manufacturing Center brought key manufacturing processes into a 75,000 m<sup>2</sup> facility, enabling high-quality, high-efficiency production and fostering innovation. A dedicated R&D team committed to developing products that meet global standards and serve diverse applications.
- Global expansion: GEIS's first Thailand facility makes it easier to serve customers worldwide.



## GEIS deliver complete range of products for the evolving electrification needs:



**SecoVac VCB**



**M-PACT Plus ACB**



**Elfa Series MCB/RCBO**



**SolidDrive MV VFD**



**SecoGear MV Switchgear**



**RMU Gas Insulated Switchgear**



**WaveCast Transformer**



**MLS LV Switchgear**

## Catalogue

### A

#### Product Description

- A.1 Brief Introduction
- A.3 Vacuum Interrupter (VI)
- A.4 Application Condition
- A.5 Applications
- A.6 Advanced Technology
- A.7 Standards and Quality Control
- A.8 Environmental Protection

### B

#### Selection Guide

- B.1 Product Structure
  - B.1 Front panel
  - B.1 Primary disconnect
  - B.1 Breaker mechanism
  - B.2 Interlock system
  - B.2 Undercart
  - B.3 Circuit Breaker Characteristics
  - B.3 Main circuit resistance of SecoVac
  - B.3 Coil Characteristics
  - B.3 Motor characteristics
- B.4 Generator Circuit Breaker and Generator Switchgear
  - B.4 Generator Faults
  - B.6 SecoVac VB2 Plus G
  - B.6 Applications
  - B.6 Benefits
  - B.7 Technical Data
  - B.8 IEC/IEEE 62271-37-013 Combined Standard
  - B.9 SubSea applications
  - B.9 Extreme vibration testing
  - B.10 Overall Dimension

### C

#### Ordering Check List

- C.1 Ordering Check List

# SecoVac

## 3.3kV-27kV Embedded Pole Vacuum Circuit Breaker

### Introduction

SecoVac series 3.3kV-27kV vacuum circuit breaker designed by GEIS is a three-phase AC indoor breaker which can be applied in controlling and protecting electrical equipment in industrial and mineral enterprises, power plants and substations.

The product conforms to the IEC62271-100 standard. It is especially suitable for conditions which require frequent operation. The breaker can be installed in the switchgear both in fixed type and withdrawable type. It is the optimum choice for the control and protection of MV power distribution systems.



## Product Description

# Reliability, safety and performance in a compact package

## SecoVac 3.3kV-27kV Vacuum Circuit Breakers Provide:



### Leading vacuum and insulation technology

GEIS has developed environmentally friendly vacuum circuit breakers which are capable of reliably switching high stress fault currents. Increased dielectric strength of the SecoVac circuit breaker is achieved through encapsulation of the vacuum interrupter in epoxy resin material. SecoVac circuit breaker family utilizes this solid insulation technology that has been catering to a wide scope of applications for years.



### Environmentally-friendly design

GEIS's vacuum and solid insulation technology is free of SF<sub>6</sub> gas that contributes significantly to the greenhouse effect and associated climate change.

### Built to highest quality standards

SecoVac circuit breakers are designed and fully third-party KEMA type tested to the latest IEC 62271-100 and IEC 62271-1 standards. All SecoVac circuit breakers meet or exceed the electrical and mechanical endurance requirements of E2 and M2 in accordance with IEC 62271-100.



### Storage conditions

In order to retain all of the functional units qualities when stored for prolonged periods, we recommend that the equipment is stored in its original packaging in dry conditions sheltered from the sun and rain at a temperature of between -15°C and 40°C. For storage: -30°C.

### Reliability and safety

SecoVac circuit breakers have a number of inbuilt safety capabilities which can be incorporated into the switchgear design. Due to its innovative operating mechanism the SecoVac breaker has industry leading reliability that is rated at 10,000 operations.



### Adaptability and versatility

SecoVac circuit breakers can be used in a wide scope of applications such as the protection of transformers, capacitor banks, motors. The breaker can be used in a wide range of environments to suit all regions of the globe.

## Product Description

### Vacuum Interrupter (VI)

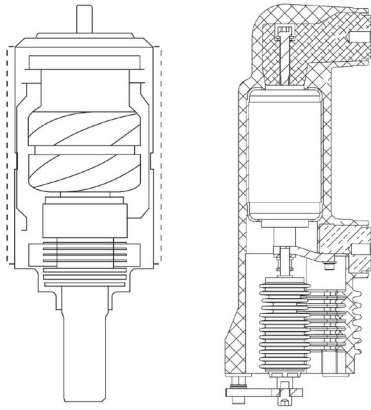

The vacuum interrupter is where current making and breaking occurs. Copper chromium contacts provide superior performance characteristics. The vacuum in the arc chamber protects the copper chromium contacts from adverse effects such as contamination and corrosion.

#### Maintenance free

Vacuum interrupters are hermetically sealed and offer extensive vacuum integrity. Dedicated to proven reliability, safety and performance, GEIS vacuum interrupting technology offers highest quality products which are sealed for life.

#### Structural durability

SecoVac circuit breaker is an embedded pole type, which is extremely durable.

It can protect the vacuum interrupter from mechanical and climatic influence such as humidity, moisture and dust. The interrupter is immune to shock and vibration.

#### High performance

SecoVac circuit breakers provide you with:

- High dielectric strength
- High creepage distance
- High mechanical strength
- Low moisture absorption
- Optimum thermal conductivity

#### Compact size

Combined with GE's embedded pole technology, SecoVac circuit breaker has a very compact design. It offers high current and interruption ratings in a small, cost effective package.

## Product Description

### Application Condition

#### High performance

- The ambient air temperature does not exceed 40°C and its average value, measured over a period of 24 hours, does not exceed 35°C. The minimum ambient air temperature is -15°C (storage and transportation is allowed at -30°C)
- For applications above 1,000m please refer to chapter 4.2.2 of IEC 60071-2 (see following table for reference)
- The conditions of humidity are as follows:
  - The average value of the relative humidity, measured over a period of 24 hours, does not exceed 95%
  - The average value of water vapor pressure, measured over a period of 24 hours, does not exceed 2.2kPa
  - The average value of the relative humidity, measured over a period of one month, does not exceed 90%
  - The average value of water vapor pressure, measured over a period of one month, does not exceed 1.8kPa
- Seismic intensity to UBC zone 4 or GB intensity 9
- No adverse operating environment such as dust, humidity, vermin, polluted ambient and high altitude operating site

#### Special application condition

If the actual application conditions differ from the normal application conditions, circuit breaker and associated devices and auxiliary equipment shall be designed and manufactured to comply with any special application conditions. For special application conditions please consult with GE in advance, normally the following special service conditions maybe encountered:

- The installation location is more than 1,000m above sea level
- The ambient temperature is between -15°C and 40°C, for other conditions please contact GE sales for further detail
- The circuit breaker current and dielectric ratings must be lowered for high altitude and elevated temperature applications
- Marine and SubSea conditions. Refer to specific chapter in the catalogue.

Altitude Derating MV

m	K (m=1)	V	K (m=0.9)	In
1,000	1	1	1	1
1,500	1.062	0.94	1.056	0.95
2,000	1.132	0.88	0.12	0.89
2,500	1.2	0.83	1.18	0.85
3,000	1.28	0.78	1.246	0.80
3,500	1.36	0.74	1.32	0.76
4,000	1.44	0.69	1.39	0.72

IEC 60071-2, 4.2.2 the altitude correction factor can be calculated using the following equation, which modified to reflect that no correction is required up to 1000m.

$$K_a = e^{m(H-1000)/8150}$$

Where

H Is the altitude, in metres

m Is taken as a fixed value in each case for simplification as follows

m = 1 for power frequency, lightning impulse and phase-to-phase switching impulse voltages

m = 0.9 for longitudinal switching impulse voltages

## Product Description

### Utilities and power plants

Network substation of Utility Grid  
Balanced of Plant in Power Generation  
Generator Switchgear



### Industry

Oil and Gas  
Mining  
Pulp and Paper  
Cement  
Textiles  
Automotive Metallurgy



### Transport

Airports  
Ports Railways  
Underground transport



### Services

Supermarkets  
Shopping malls  
Hospitals  
CBD  
Data Center

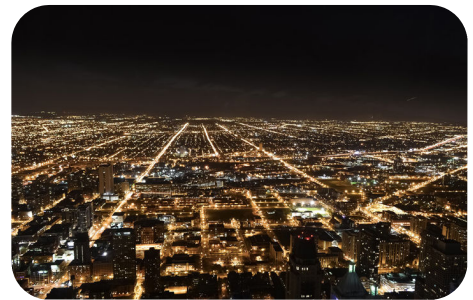

# Applications

## Product Description

### Advanced Technology

#### High adaptability

- Compare to traditional design, enhanced reliability
- Less resistance
- Less mechanical parts
- Various applications for different climates



### Standard and Quality Control

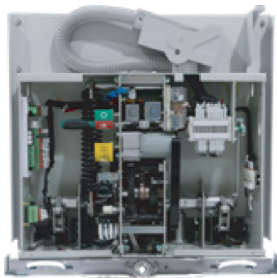
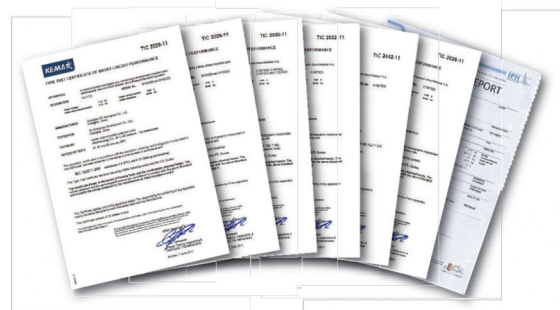

#### Quality

SecoVac circuit breakers provide you with:

- IEC standard, 3rd party KEMA certification
- Advanced manufacturing process ensured quality
- Advanced testing equipment
- Integrated routine test

#### Type test

- Dielectric test
- Temperature rise test
- Short circuit withstand current test
- Mechanical operation test
- ES-Mechanical operation test
- Capacitive current switching test

#### Mechanical structure

- Single modular design
- Integrate closing/opening module
- Compact size, less than 86 parts
- Enhanced reliability
- Low maintenance



#### Standard

3.3kV-27kV Embedded Pole Vacuum Breaker complies with the standards and specifications and has been type tested in accordance with the following IEC publications:

- IEC 62271-100 high-voltage alternating current circuit breaks
- IEC 62271-200 AC metal enclosed switchgear and control gear for rated voltages above 1kV and up to 52kV

- Alternating current disconnectors and earth switches
- IEC 62271-1 the common specification for high voltages switchgear and control gear standards
- IEC 60529 degrees of protection as provided by enclosures (IP code)

## The state-of-the-art processing and advanced quality control

The high quality of the embedded pole is achieved by using the latest APG (Auto Pressure Gelation) technology and advanced vacuum mixing and degassing technology. The Vogel clamping machine is an essential piece of equipment to ensure the mechanical and insulating strength of the embedded pole of 3.3kV-27kV series MV embedded pole vacuum circuit breaker. As well as the processing facilities, the testing facilities are also very important to the quality control of the breaker. In the manufacturing process of SecoVac, from incoming material quality control to the final inspection and testing, every step is strictly calibrated and tested.

Every embedded pole goes through the following inspection and testing before it is allowed into the breaker assembly line:

- X-ray inspection
- Power frequency withstand voltage test
- Partial discharge measurement
- Thermal cycling test

Before delivery, the following tests and inspections will be done for 3.3kV-27kV embedded pole vacuum circuit breakers in factory by means of advanced testing equipment:

- Dynamic characteristics measurement (Closing/opening speed, contact bounce, wipe etc.)
- Power frequency withstand voltage testing
- Inspection of interlocking system between breaker and withdrawable unit
- Secondary wiring inspection
- Circuit resistance measurement

# Quality Control

## Product Description

### Environmental Protection

Selecting low environmental impact technologies has become increasingly important when choosing equipment for an application. With commitment to environment protection, the solid insulation of epoxy resin is used for 3.3kV-27kV series MV embedded pole vacuum circuit breaker instead of SF6 gas.

Manufactured, assembled and tested all in the same sophisticated facility, SecoVac is the product of state-of-the-art manufacturing processes assured by ISO 9001:2000 and ISO 14001 certification. Using precision tools, computer-aided design and advanced production techniques.



## Product Structure

### SecoVac 3.3kV-27kV Breaker Features



#### Front panel

Front panel fits into a collar frame in the equipment when the breaker is in the service position. It provides a metal barrier between the breaker compartment and the secondary device compartment.

Clearly marked and easy-to-read operating controls and indicators include trip button, close button, open/close indicator, charge/discharge indicator, operations counter and provision for manually charging the breaker.

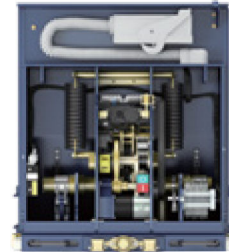

#### Breaker mechanism

All the mechanical parts of the mechanism are integrated into individual opening and closing modules. The modules are universal to SecoVac embedded pole vacuum circuit breaker series, regardless of rating. The module design assures no mechanical adjustment is required after replacement. This offers the user shorter lead-times and reduces operational and maintenance costs.



#### Primary disconnect

The primary disconnect cycloid (tulip) contact set is rugged and easy-to-inspect. Designed for optimum contact area, it is manufactured from silver-plated copper and tested for continuous and short-circuit current ratings. The tulip cluster design expands easily, providing better finger contact area than flat type contact designs, and delivering proper contact integrity throughout the life of the equipment.

## Selection Guide

### Interlock system

For personnel safety, SecoVac 3.3kV-27kV is designed with a number of mechanical and electrical interlocks. For example, breaker contacts must be open before the breaker can be moved from test to service position. A positive mechanical stop is provided when the breaker reaches the service or test/disconnect positions. Mechanical rejection interlocks are provided to permit only the insertion of properly rated breakers into specific compartments.

These and other necessary interlocks provide a comprehensive safety system. Furthermore, springs automatically discharge when the breaker is withdrawn from the service position and breakers cannot be inserted in the closed position.

### Undercart

Secogear and SecoBloc offers manual operation undercart system which can be operated for racking in and out. The undercart has an interlock with earthing switch, which prevents misoperation. And it also allows earthing function of circuit breaker by means of metallic structure.

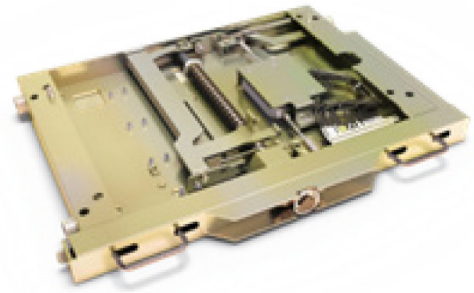

### Typical layout for vacuum circuit breaker

- 1** Tripping button
- 2** Status indicator for charging
- 3** Closing button
- 4** Counter
- 5** Indicator for open or close
- 6** Charging handle



Figure 1. Front facial of the circuit breaker

- 1** Upper contact arm
- 2** Embedded poles
- 3** Lower contact arm
- 4** Tulip cluster

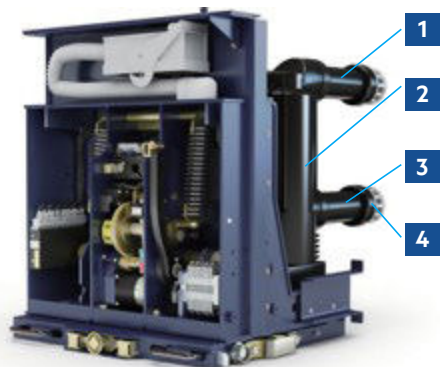

Figure 2. Primary circuit

## Selection Guide

### Circuit Breaker Characteristics

Rated Voltage	kV	7.2	12	15	17.5	24	27
Rated power frequency withstand (1min)	kV	20	28	36	38	50	60
Rated lightning frequency impulse withstand voltage (1.2/50 $\mu$ s)	kVp	60	75	95	95	125	125
Rated Frequency	Hz	50/60				50 / 60	
Rated Current	A	630/1250/1600/2000/2500/3150/4000*				1250, 2500, 3150*	
Rated short-circuit breaking current	kA	25/31.5/40/50				31.5	
Percentage of DC component		Up to 50%				52%	
Rated short-circuit closing current	kAp	65/82/104/130				82	
Rated short time withstand current	kA	25/31.5/40/50				31.5	
Rated peak value withstand current	kAp	65/82/104/130				82	
Rated duration time for short-circuit	s	3				3	
Opening Time	ms	20-50				20-50	
Closing Time	ms	30-70				30-70	
Rated auxiliary control voltage	V	24/36/48/60/110/220 V DC 110/220 V AC					
Mechanical life operations	Quantity	15,000 (M2)				10,000 (M2)	
Electrical Endurance class		E2				E2	
Single capacitor bank Switching current	A	400				400	

\* Force cooling

\*\* 3 phase back to back capacitor bank switching current 630A only for 17.5kV 3150A 40kA breaker

### Main circuit resistance of SecoVac

Item	Unit	Value	
Rated Current	A	1250~1600	2000~4000
Resistance	$\mu\Omega$	$\leq 45$	$\leq 25$

### Coil Characteristics

Rated Voltage (DC.V)	Resistance Value ( $\Omega$ )	Rated Current (A)	Inrush Current (A)	Maximum Power (W)
110 (DC/AC)	51	2.2	12.9	237.3
220 (DC/AC)	198	1.1	6.7	244.4
24	1.8	13.3	80	320
24	1.3	18.5	110.8	443.1
30	1.6	18.8	112.5	562.5
36	3.1	11.5	69.2	415.4
48	3.1	15.5	92.9	743.2
60	10.8	5.6	33.4	334
125 (DC/AC)	45	2.8	16.7	347.2
230-240 (DC/AC)	320	0.7-0.8	4.3-4.5	165.9-180
250 (DC/AC)	216	1.2	6.9	289.4

### Motor Characteristics

Rated voltage (V)	Normal operation voltage range	Charging time at rated voltage (s)	Input Power (W)
DC 24	85%-110%	<15s	150
DC 30	85%-110%	<15s	150
DC 48	85%-110%	<15s	150
DC 60	85%-110%	<15s	150
DC 110	85%-110%	<15s	150
DC 125	85%-110%	<15s	150
DC 220	85%-110%	<15s	150
DC 230-240	85%-110%	<15s	150
AC 110	85%-110%	<15s	150
AC 125	85%-110%	<15s	150
AC 220	85%-110%	<15s	150
AC 230-240	85%-110%	<15s	150

## Selection Guide

### Generator Circuit Breaker and Generator Switchgear

#### Generator Faults

The fault conditions in the proximity of a generator source are more demanding than those in normal distribution circuits. These special fault characteristics require specifically designed and tested circuit breakers.

The critical points to be considered are:

#### Generator Circuit Configuration

As a result of the circuit configuration, two key unique fault current conditions are encountered by generator circuit breakers (figure 1).

#### System-source short-circuit current

The short circuit fed by the transformer (point "a", figure 1) on the generator side leads to high thermal and mechanical stresses on the vacuum interrupters because the full energy of the power system feeds the fault. To clear these faults, Generator Circuit Breakers are capable to interrupt not only the symmetrical fault but also the higher asymmetrical fault currents with a DC component of up to 75%. This will be the maximum short circuit current the breaker needs to interrupt with peak making and withstand capacity of 2.74 times the RMS current.

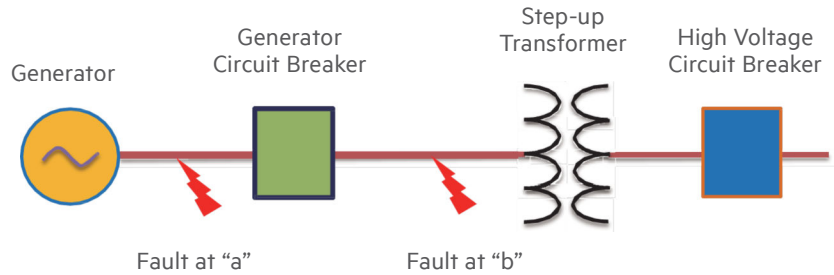

#### Generator-source short-circuit current

If there is a short circuit (point "b", figure 1) the current is fed by the generator on the transformer side. The fault currents, while relatively smaller in magnitude, are subject to a phenomenon called Delayed Current Zero. This unique characteristic is a result of the very high X/R ratio of the circuit and the operating conditions of the generator, which can combine to produce a DC component of the fault current exceeding 100%. The asymmetrical fault current peak becomes so high and its decay becomes so slow, that the current zero can be delayed for several cycles.

As vacuum interrupters rely on a current zero to break the current, the delay it results in longer arcing time with extreme thermal stress on the interrupter.

The generator circuit breakers are tested according to IEC/IEEE 62271-37-013 to withstand the high electrical, thermal and mechanical stress during the interruption of fault currents with a DC component of up to 130 %. Normally this short circuit current will be 50% of system source short circuit current with very high DC component.

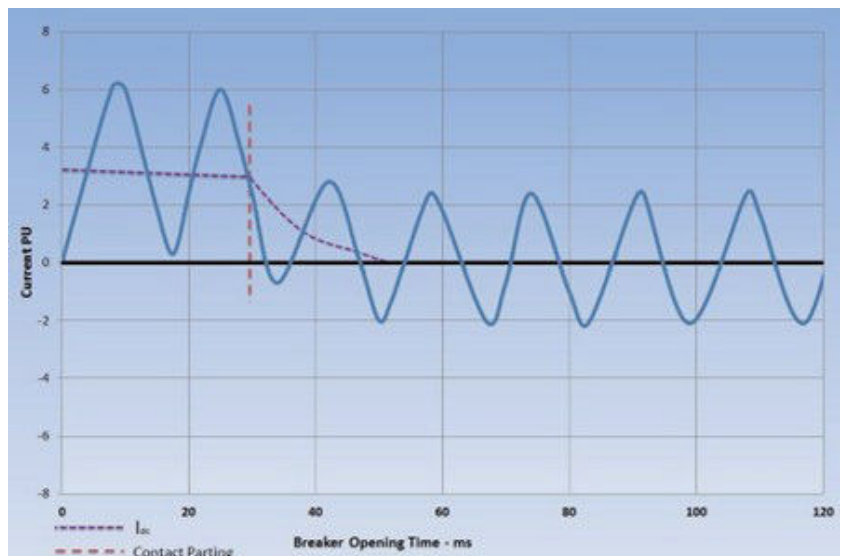

## Selection Guide

### Unique Voltage Conditions

Generator circuits are typically designed for high efficiency in order to minimize the power loss of the system. Therefore, the generator circuit breaker may be located very close to both the generator and transformer, connected by short conductors with a large cross-section, resulting in a very low resistance and low stray capacitance. These characteristics combine to produce very high natural circuit frequencies resulting in extreme Transient Recovery Voltages (TRV) with high Rates of Rise of Recovery Voltage (RRRV).



### Transient Recovery Voltages (TRV)

The circuit produces the peak value of TRV, which is nearly double the line-to-line system voltage, across the contacts within microseconds following the current zero. The Vacuum Interrupter must re-establish dielectric strength across the open contacts gap in order to withstand this fast rising TRV. If the interrupter is able to withstand that voltage, then the interruption is successful.

### Transient Recovery Voltages (TRV)

An important factor is how fast the TRV rises across the recovering gap after current zero. This is measured by the RRRV, which is proportional to the peak value of the transient voltage in kV, divided by the time it takes the voltage to reach that peak value in microseconds.

Values for standard Medium Voltage distribution circuits are in the range of 0.4 to 1 kV /microsecond, while RRRV values for generator circuits are about 3.5 kV / microsecond.

These characteristics were tested for the first time at the KEMA laboratories in Netherlands using a Direct on Line connection with GE's SecoVac VB2+G Generator Vacuum Circuit Breaker.

### Transient Recovery Voltages (TRV)

The out-of-phase voltage conditions can occur during normal start-up when the generator and power system voltages are not in sync. Initially, the generator is off and the generator circuit breaker is in the open position with the power system operating. The voltage across the open circuit breaker contacts is equal to the normal power system voltage. When additional or emergency power is desired, the generator is started and begins to produce voltage. As the generator comes up to speed, the generator output voltage and frequency slowly increase. This causes the voltage across the open contacts of the circuit breaker to vary.

IEC/IEEE 62271-37-013 requires that the generator circuit breaker can switch off under out-of-phase conditions (out-of-phase angle 90°) while the voltages across the open contacts can be as high as twice the rated line-to-ground voltage of the system.

## Selection Guide

### SecoVac VB2 Plus G

Performance requirements for Generator Circuit Breakers are specified in the IEC/IEEE 62271-37-013 standard. This is a combined standard intended to replace the IEEE C37.013 and fill the gap of the IEC which has never had a generator breaker standard previously.

SecoVac VB2 Plus G 15kV have passed all the Type Tests as per the new IEC/IEEE combined standard, becoming the first Generator Circuit Breaker of the SecoVac family.

The standard SecoVac VB2 Plus breaker and the SecoVac VB2 Plus G generator circuit breaker can be used in all SecoGear IEC switchgear panels. With the same functionality and footprint of conventional IEC Switchgear while getting all the benefits from a fully proven Generator Circuit Breaker.

SecoVac VB2 Plus G can also be installed in SecoBloc modules, producing the perfect combination for OEM manufacturers building generator switchboards.

### Applications

A properly protected generator unit increases its levels of reliability, availability and safety, and by extension the same for the complete electrical system where is being operated. Even the smaller generator units can produce high DC component or Transient Overvoltage levels requiring special breakers intended to protect such fault conditions.

With this new addition to the SecoVac family, SecoGear is perfectly set to protect Generators. Applications up to 60MVA, 31.5kA, 15kV can be operated with SecoVac VB2 Plus G. These power output ranges are commonly used on:

- Distributed Power Generation
  - Diesel/Gas Engines
  - Small Frame Gas Turbines
  - Aero Derivative Turbines
- Marine Diesel-Electric Generators
- Oil and Gas Start-up/Back-up Generator units
- Mining Power Plants
- Small Hydro
- Small Steam Turbines

### Benefits

The SecoVac VB2 Plus G generator circuit breaker is based upon the same design principles as our distribution type SecoVacVB2+ breaker this results in advantages for electrical designers, operating personnel and maintenance staff.

The SecoVac VB2 Plus G is designed to be fitted into GEIS's SecoGear range of medium voltage type tested IEC panels. The SecoGear range can accommodate generator, distribution circuit breakers and fuse contactors within the same standard panel design offering industry leading safety, reliability and performance features to meet the requirements for all Medium Voltage Distribution in Power Plant applications.

In addition to being able to be supplied as part of a complete switchgear lineup, SecoVac VB2 Plus G can be supplied as part of GE's SecoBloc OEM modules. SecoBloc is designed specifically to allow OEM panel builders to incorporate a type tested circuit breaker and cable compartment into their customer built switchboard arrangement. VB2 Plus G modules are available in various configurations to suit specific generator applications.

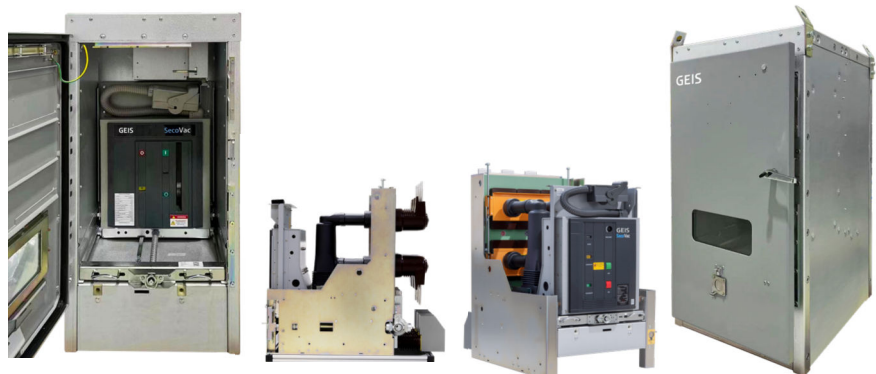

## Selection Guide

### Technical Data

Rated short-circuit breaking current	kA	31.5		40		50	
Rated Voltage	kV	15		15		15	
Rated Current	A	2500/3150/4000*		2500/3150/4000*/5000*		2500/3150/4000*	
Rated Frequency	Hz	50/60		50/60		50/60	
Rated power Freq withstand voltage (1 min)	kV	38		38		38	
Rated lightning impulse withstand voltage	kVp	95		95		95	
Operation sequence		CO – 30min - CO		CO – 30min - CO		CO – 30min - CO	
Generator Circuit Class		G2		G2		G2	
<b>Location of fault</b>		'a' – System supplied fault	'b' – Generator supplied fault	'a' – System supplied fault	'b' – Generator supplied fault	'a' – System supplied fault	'b' – Generator supplied fault
Rated short-circuit breaking current	kA	31.5	15.8	40	25	50	25
Rated short-circuit making current: I <sub>peak</sub>	kAp	86.3	34.1	110	54	137	54
Interrupting Time	ms	50		50		50	
Minimum Opening Time	ms	24.3		24.3		24.3	
Degree of Asymmetry	%	75	130	75	130	75	130
Asymmetry interrupting capability	kAp	46	34.1	58.4	36.5	73	36.5
Close and Latch Capability	kAp	86.3		110		110	
Rated short time withstand current	kA	31.5	N/A	40	N/A	50	N/A
Rated duration time for short-circuit	s	3	N/A	3	N/A	3	N/A
Rate of Rise of Recovery Voltage (RRRV)	kV/μs	3.5	3.5	3.5	3.5	3.5	3.5
Peak Recovery Voltage	kV	27	27	27	27	27	27
<b>Out-of-Phase Current Switching</b>							
Duty Voltage	kV	21.2	N/A	21.2	N/A	21.2	N/A
Breaking Current	kA	15.8	N/A	20	N/A	25	N/A
Max. Making Current (V-0)	kAp	31.5	N/A	40	N/A	40	N/A
Rate of Rise of Recovery Voltage (RRRV)	kV/μs	3.3	N/A	3.3	N/A	3.3	N/A
Peak Recovery Voltage	kV	39	N/A	39	N/A	39	N/A
Mechanical life operations:	Number	10000		10000		10000	
Center distance between phase	mm	275		275		275	

\* Is VCB with force cooling.

## Selection Guide

### IEC/IEEE 62271-37-013 Combined Standard

Up until the development of a common IEC / IEEE standard for generator circuit breakers there was no IEC standard to cover the special needs of circuit breakers being used in generator application.

Commonly users were referring to the IEEE standard for generator application.

#### History

The IEC proposed to have a standard covering the generator circuit breakers in November 2008, and started activities to develop it after approval of the proposal in April 2009.

Firstly the Standard was named IEC 62271-112, and later on moved to IEC 62271-37-013 and target of the project broaden to jointly revise IEEE Std C37.013 with IEEE under the IEC/IEEE Dual Logo -Joint Development Agreement- Liaison with IEEE Switchgear Committee.

The document is pending to be officially released in the first months of 2015 with the official title: IEC/IEEE 62271-37-013 Ed. 1.0 High-voltage switchgear and Controlgear - Part 37-013: Alternating current generator circuit-breakers

#### Improvements to IEEE C37.013

The new IEC/IEEE dual standard has several improvements compared to the previous IEEE standard.

- It has included the definition of several concepts in Clause 3.1, helping both IEEE and IEC users of this document to have same understanding of terms as they are used in this document readily available
- Included explanations of why certain requirements are needed in generator circuit-breaker applications that may not be needed for standard distribution circuit-breakers page 13
- The clauses covering generator-source fault current requirements have been greatly expanded in section 8.103.5.3 to explain how to treat the extremely high degrees of asymmetry that may occur under certain conditions
- Expanded the application section, clause 8, in order to make the selection of a generator circuit-breaker easier for users, will enable the user to be sure he has chosen the right circuit-breaker to protect their particular generator circuit

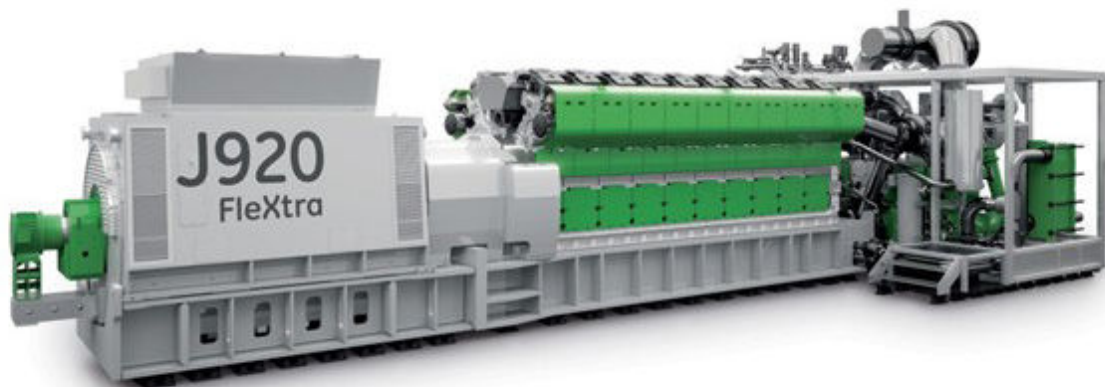

# Selection Guide

## SubSea applications

SecoVac VB2 Plus 27kV has successfully passed strict tests for SubSea applications, proving its robustness, and versatility for operation under severe conditions.

### Extreme Temperature Testing

- Storage

ISO 13628-6: 2006, Clause 5.4.2.4.

The breaker is held inside an environmental chamber in open condition for 16 hours at -30°C, then the temperature is returned to ambient temperature and the breaker is operated with CLOSE / OPEN operations carried out 5 times at minimum control voltage, rated control voltage and maximum and control voltage



- Low temperature test

IEC 62271-100 Clause 6.101.3 -18°C for 48 hrs.

The breaker is held in the closed position at -18°C for 24h. Then the breaker is operated with CLOSE / OPEN operations carried out 5 times at -18°C, at rated control supply voltage.



- High Temperature test

IEC 62271-100 Clause 6.101.3, +70°C for 48 hrs.

The high temperature test is to be performed immediately after low temperature test.

The breaker is held in the closed position at +70°C for 24h. Then the breaker is operated with CLOSE / OPEN operations carried out 5 times at +70°C, at rated control supply voltage.



### Extreme vibration testing

Vibration tests were conducted in 3 steps.

- Class 2M1 IEC 60721-3-2 and IEC 60721-4-2 (ref Sheet2)
- Real life conditions for a North Sea Project
- Real life conditions for a North Sea Project with Safety factor 2x

Below table represents the acceleration factors.

Frequency (Hz)	Acceleration amplitude (g)		
	IEC	North Sea Conditions	2x North Sea
2	0.1	0.02	0.04
4	0.4	0.8	1.6
11	1.0	0.8	1.6
100	1.0	0.04	0.08

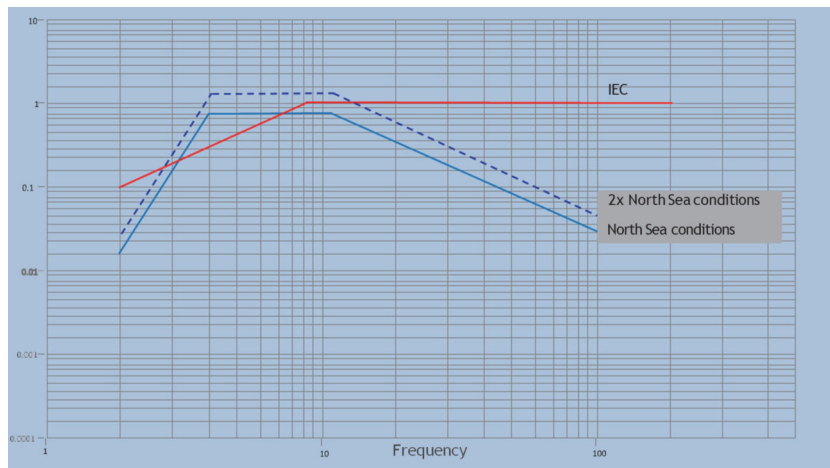

## Selection Guide

3.3kV ~ 12kV/630~1250A—25kA, 31.5kA (P=150mm)

### Withdrawable type

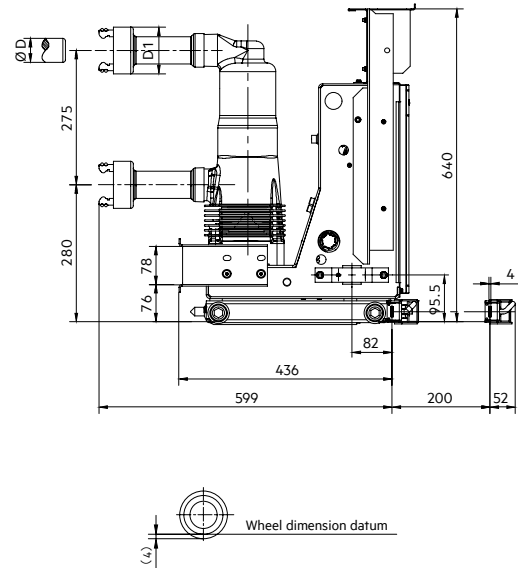
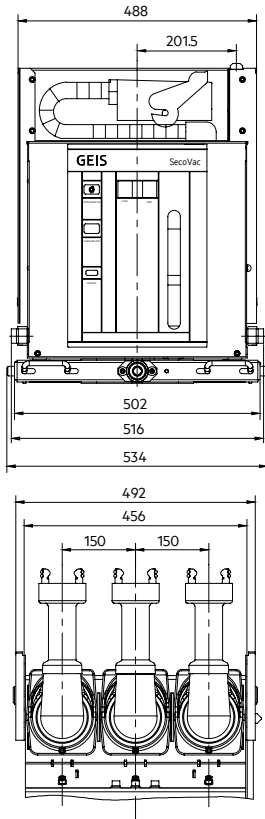

Specification (spring mechanism)	D	D1	Net weight (kg)
630A/25~31.5kA	Ø35	Ø84	100
1250A/25~31.5kA	Ø49	Ø97	105

### Fixed type

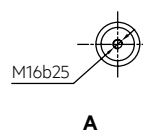
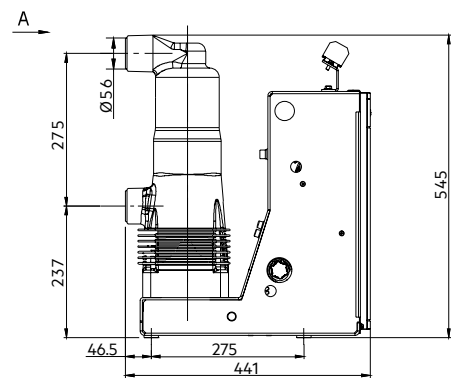
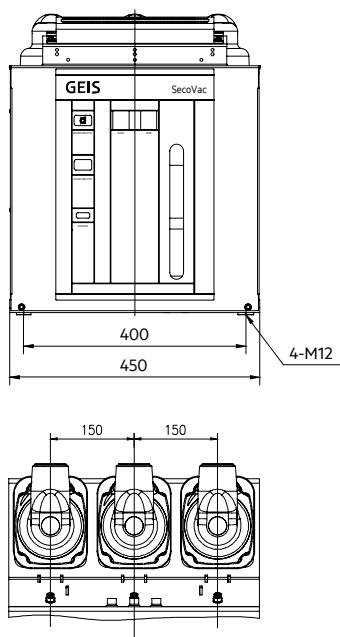

Specification
630A/25~31.5kA
1250A/25~31.5kA

# Selection Guide

3.3kV ~ 12kV/1250~1600A—31.5kA, 40kA (P=210mm)

## Withdrawable type

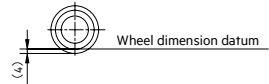
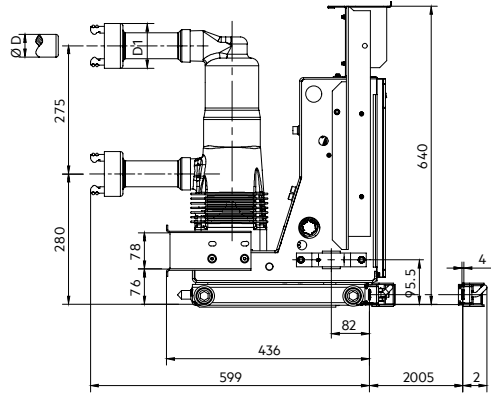
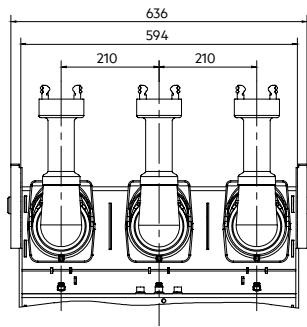
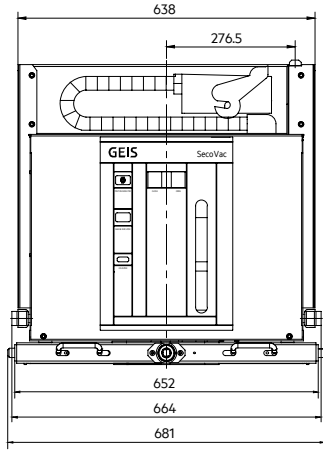

Specification (spring mechanism)	D	D1	Net weight (kg)
630A/25~31.5kA	Ø35	Ø84	110
1250A/25~31.5kA	Ø49	Ø97	115
1250A/40kA	Ø49	Ø97	120
1600A/31.5~40kA	Ø55	Ø104	130

## Fixed type

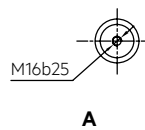
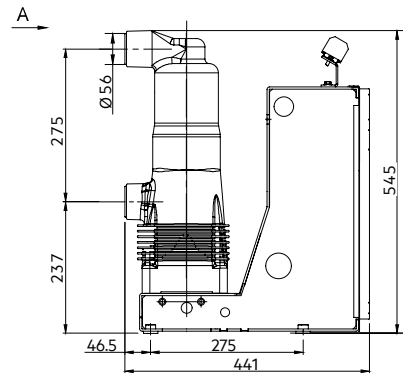
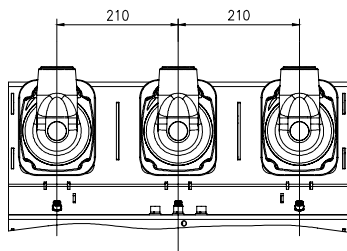
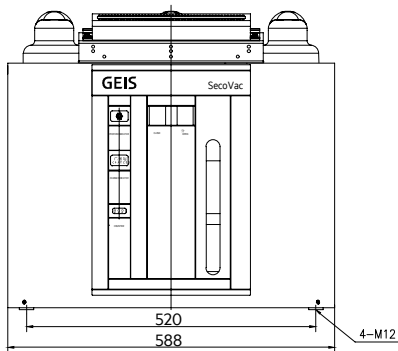

Specification
630A/25~31.5kA
1250A/25~31.5kA
1250A/40kA
1600A/31.5~40kA

## Selection Guide

3.3kV ~ 12kV/1600~2000A—31.5kA, 40kA (P=275mm)

### Withdrawable type

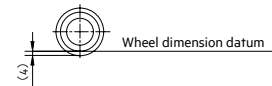
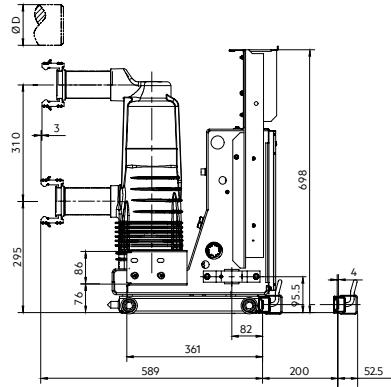
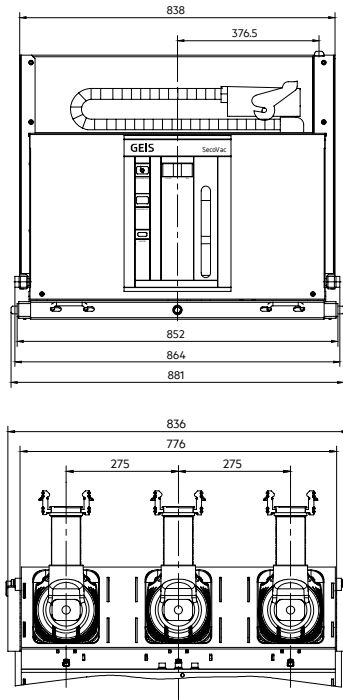

Specification	D
1600A/31.5~40kA	Ø79
2000A/31.5~40kA	Ø79

### Fixed type

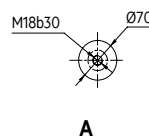
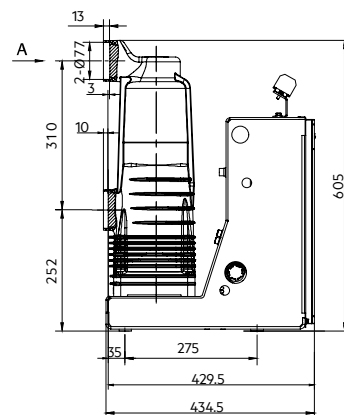
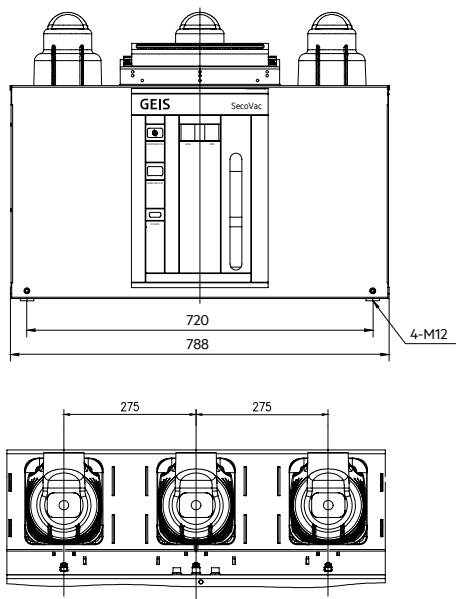

Specification
1600A/31.5~40kA
2000A/31.5~40kA

# Selection Guide

3.3kV ~ 12kV/2500~4000A—31.5kA, 40kA (P=275mm)

## Withdrawable type

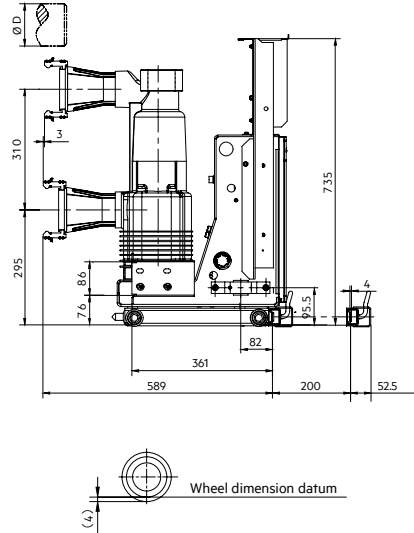
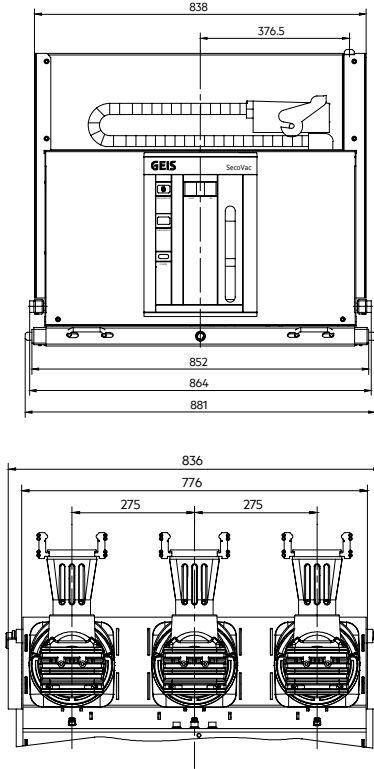

Specification	D
2500A/31.5~40kA	Ø109
3150A/31.5~40kA	Ø109
4000A/40kA	Ø109

## Fixed type

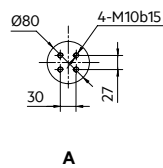
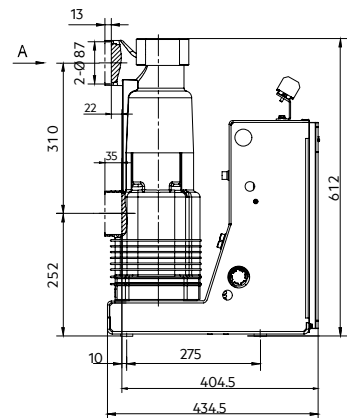
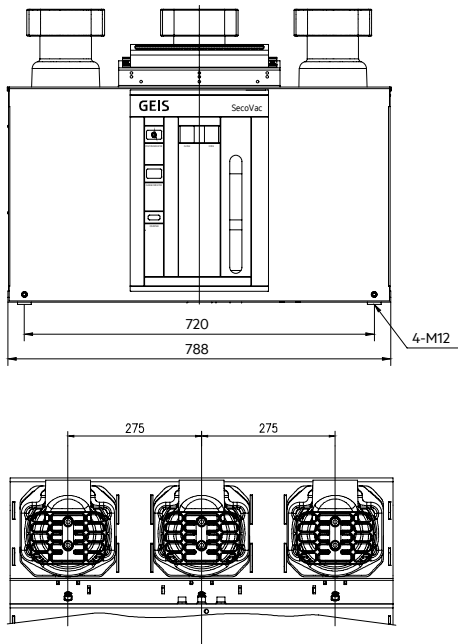

Specification
2500A/31.5~40kA
3150A/31.5~40kA
4000A/40kA

# Selection Guide

**17.5kV/630~1250A—25kA, 31.5kA (P=150mm)**

## Withdrawable type

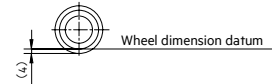
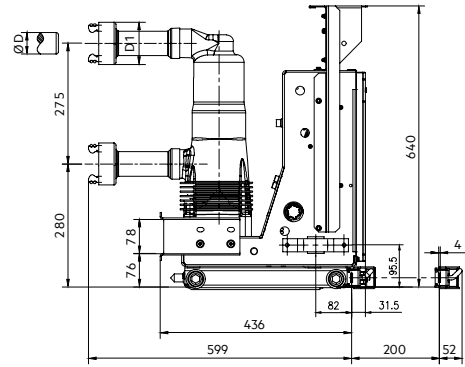
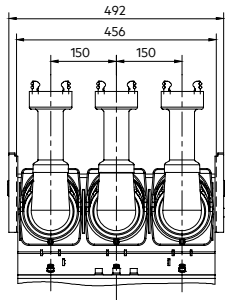
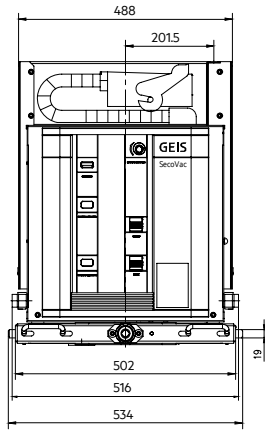

Specification (spring mechanism)	D	D1	Net weight (kg)
630A/25~31.5kA	Ø35	Ø84	Ø100
1250A/25~31.5kA	Ø49	Ø97	Ø105

## Fixed type

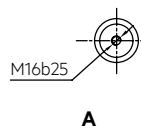
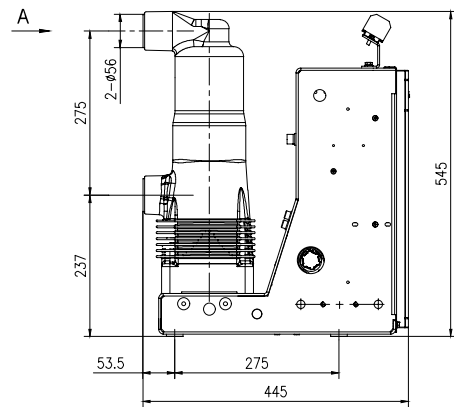
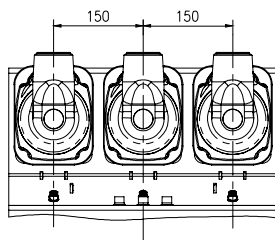
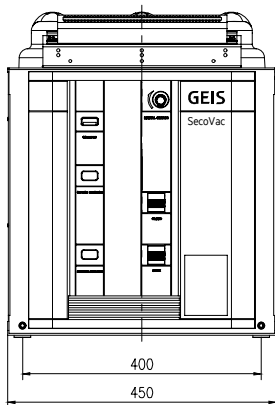

Specification
630A/25~31.5kA
1250A/25~31.5kA

# Selection Guide

**17.5kV/630~1600A—25kA, 31.5kA (P=210mm)**

## Withdrawable type

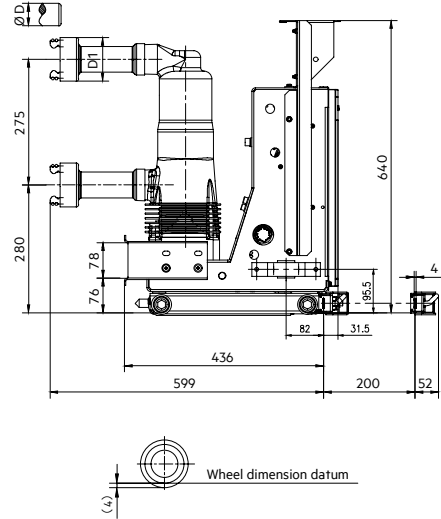
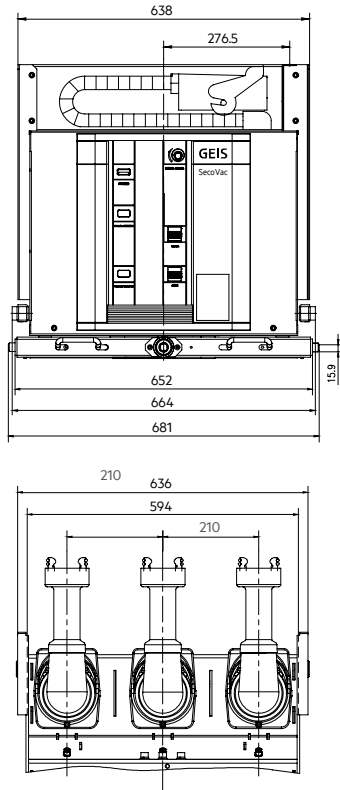

Specification (spring mechanism)	D	D1	Net weight (kg)
630A/25~31.5kA	Ø35	Ø84	110
1250A/25~31.5kA	Ø49	Ø97	115
1250A/40kA	Ø49	Ø97	120
1600A/31.5~40kA	Ø55	Ø104	130

## Fixed type

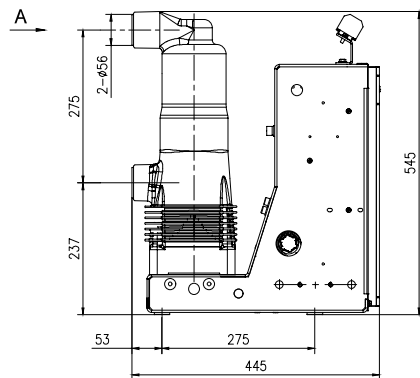
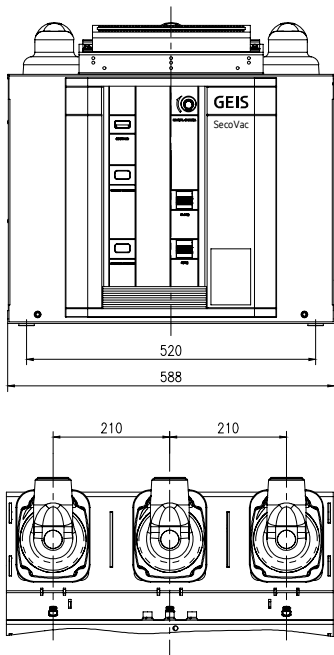

Specification
630A/25~31.5kA
1250A/25~31.5kA
1250A/40kA
1600A/31.5~40kA

## Selection Guide

17.5kV/1600~2000A—31.5kA, 50kA (P=275mm)

### Withdrawable type

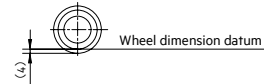
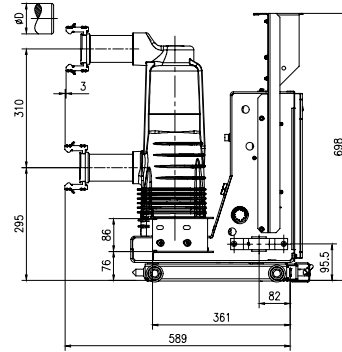
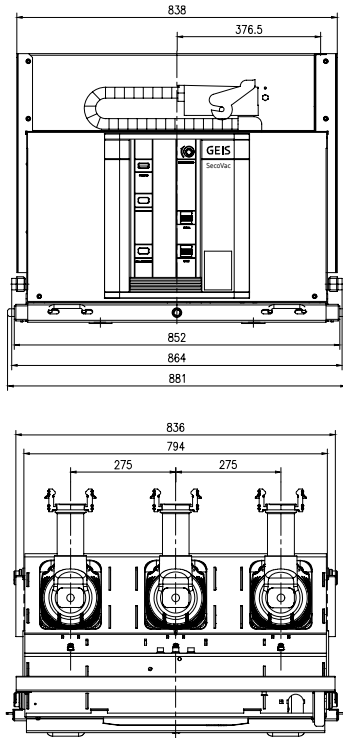

Specification	D
1600A/31.5~50kA	Ø79
2000A/31.5~50kA	Ø79

### Fixed type

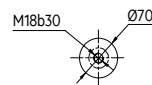
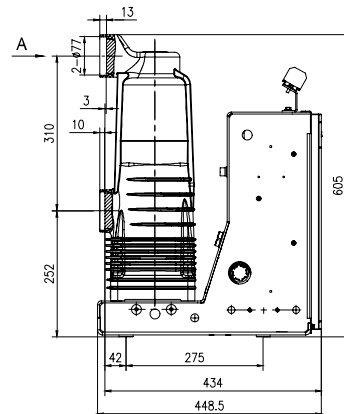
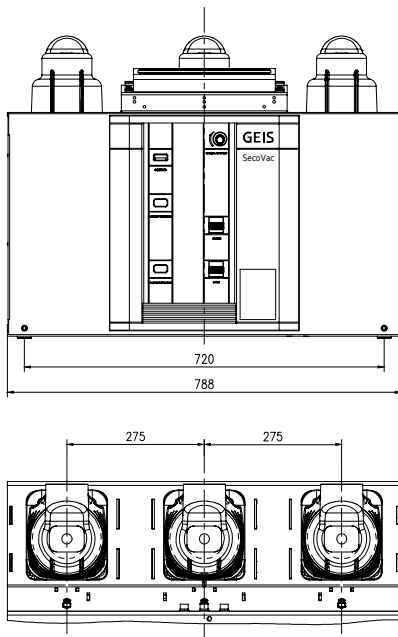

A

Specification
1600A/31.5~50kA
2000A/31.5~50kA

# Selection Guide

17.5kV/2500~4000A—31.5kA, 50kA (P=275mm)

## Withdrawable type

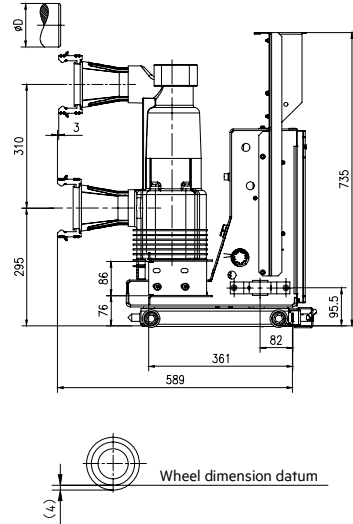
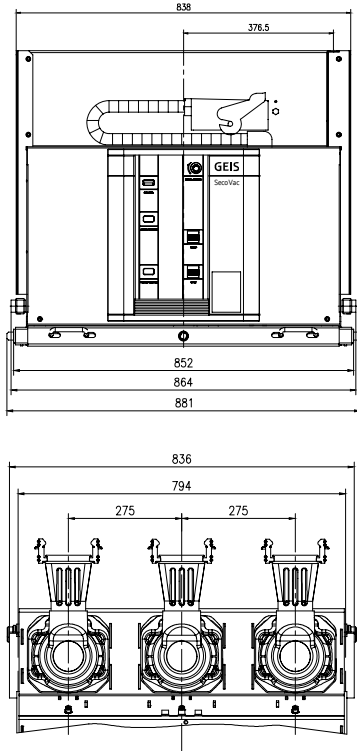

Specification	D
2500A/31.5~50kA	Ø109
3150A/31.5~50kA	Ø109
4000A/40~50kA	Ø109

## Fixed type

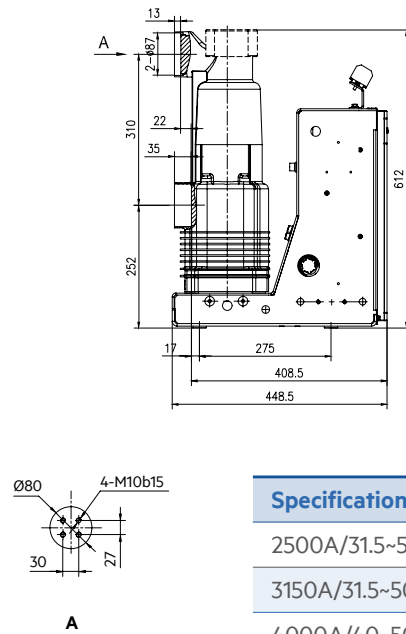
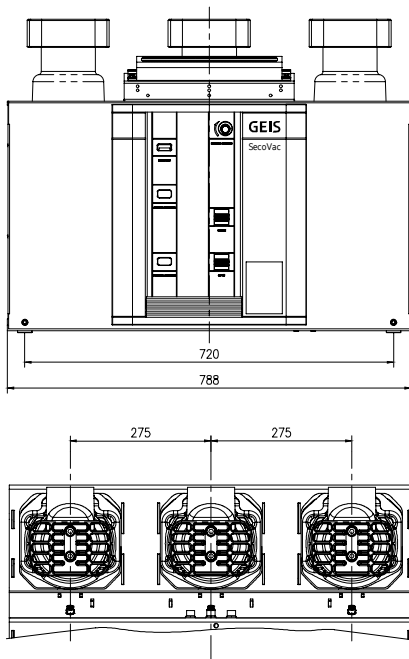

Specification
2500A/31.5~50kA
3150A/31.5~50kA
4000A/40~50kA

## Selection Guide

24kV ~ 27kV/630~1600A—25kA, 31.5kA (P=210mm)

### Withdrawable type

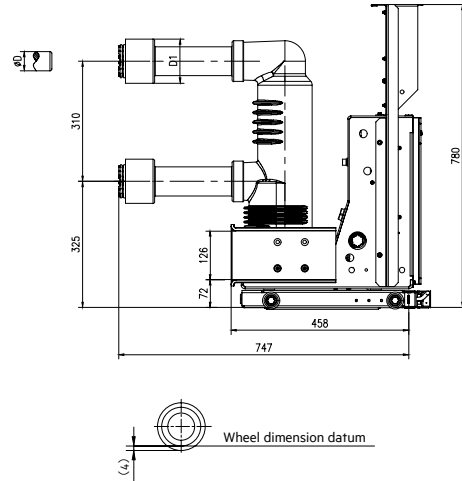
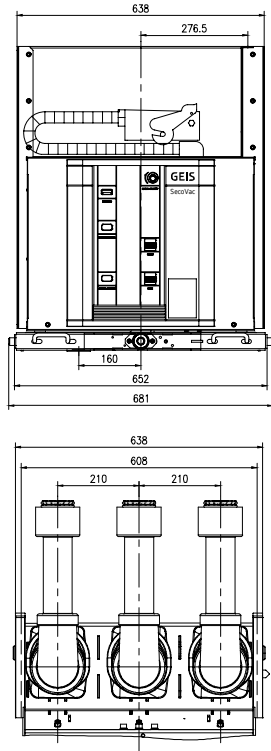

Specification	D	D1
630A/25~31.5kA	Ø35	Ø114
1250A/25~31.5kA	Ø49	Ø114
1600A/31.5kA	Ø55	Ø114

### Fixed type

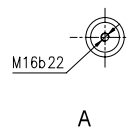
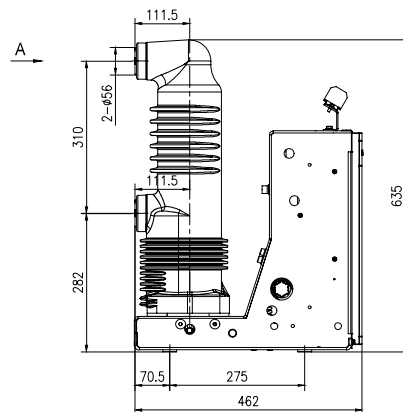
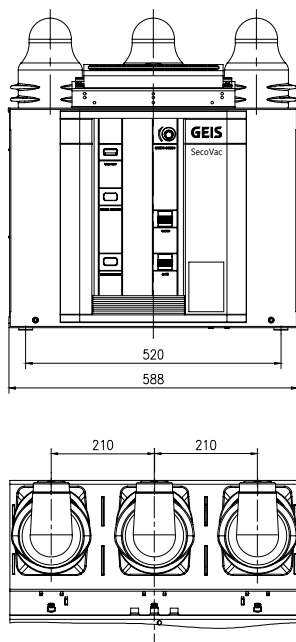

Specification
630A/25~31.5kA
1250A/25~31.5kA
1600A/31.5kA

# Selection Guide

24kV ~ 27kV/630~1600A—25kA, 31.5kA (P=275mm)

## Withdrawable type

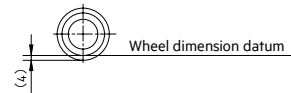
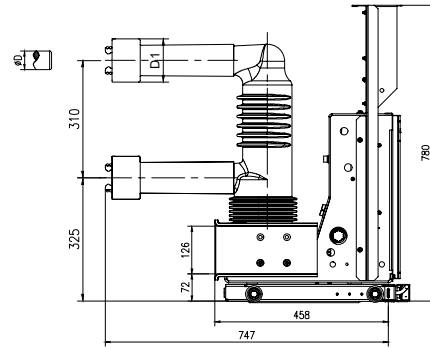
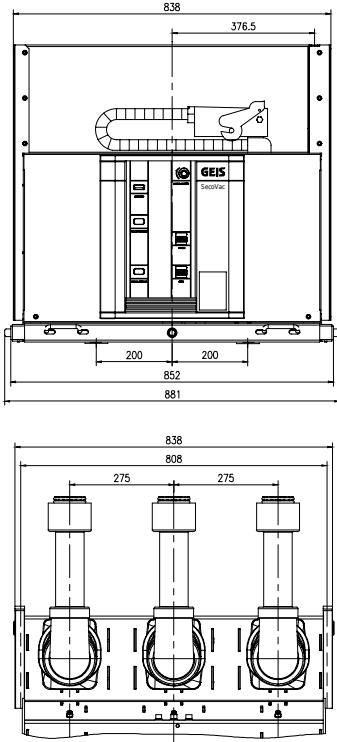

Specification	D	D1
630A/25~31.5kA	Ø35	Ø114
1250A/25~31.5kA	Ø49	Ø114
1600A/31.5kA	Ø55	Ø114

## Fixed type

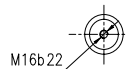
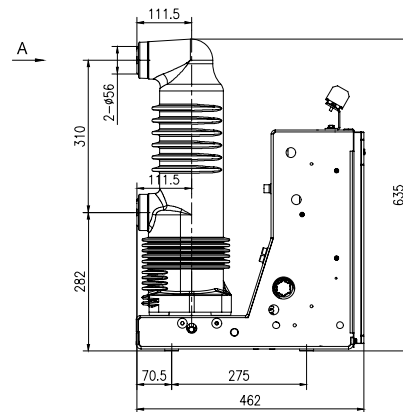
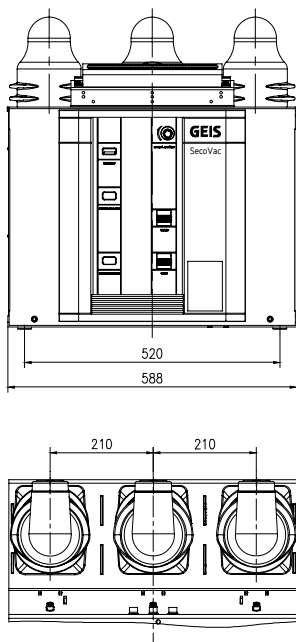

Specification
630A/25~31.5kA
1250A/25~31.5kA
1600A/31.5kA

## Selection Guide

24kV ~ 27kV/2000A—25kA, 31.5kA (P=275mm)

### Withdrawable type

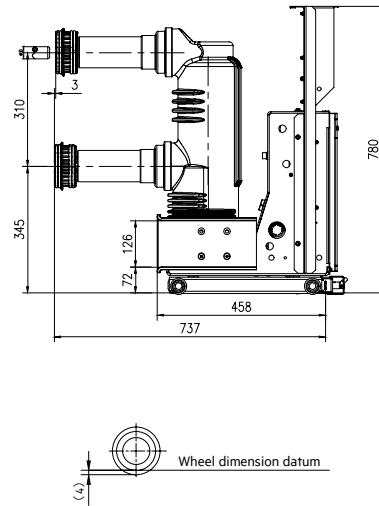
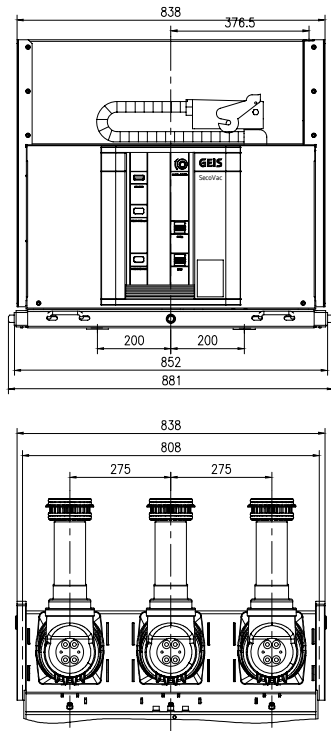

Specification	D
2000A/25~31.5kA	Ø79

### Fixed type

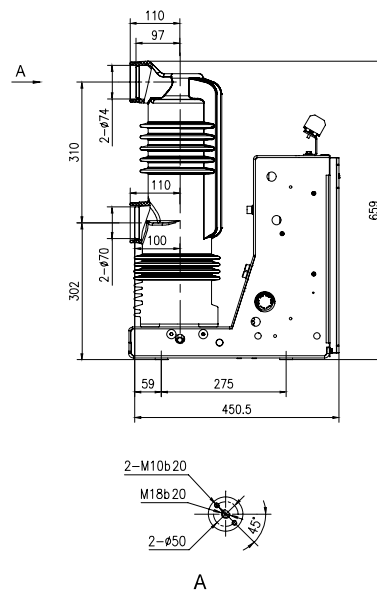
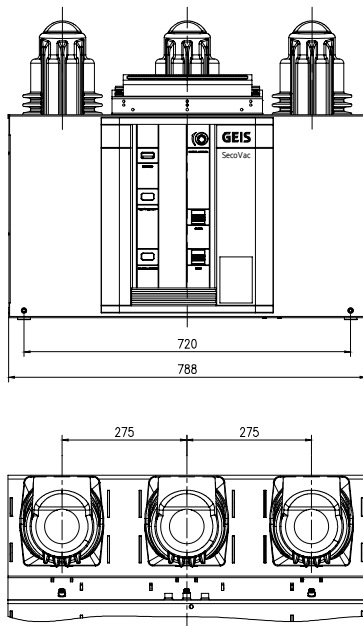

Specification	D
2000A/25~31.5kA	Ø79

# Selection Guide

24kV ~ 27kV/2500~3150A—25kA, 31.5kA (P=275mm)

## Withdrawable type

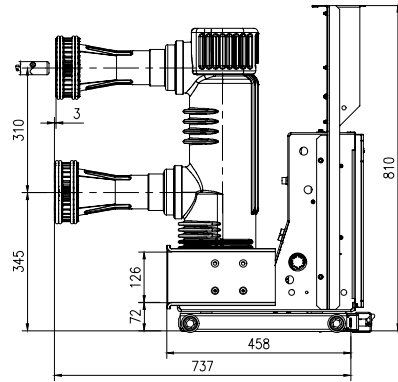
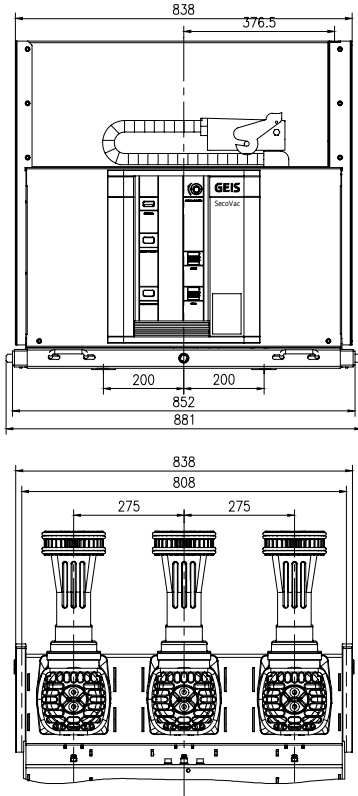

Specification	D
2500A/25~31.5kA	Ø109
3150A/25~31.5kA	Ø109

## Fixed type

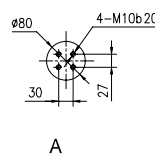
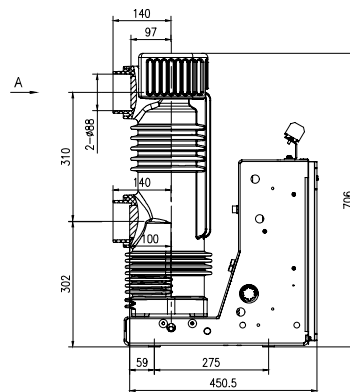
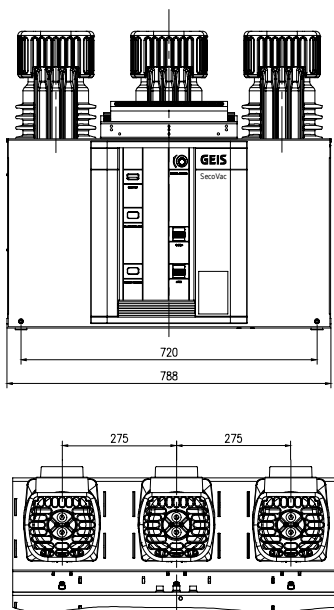

Specification
2500A/25~31.5kA
3150A/25~31.5kA

# Selection Guide

## Withdrawable (58Pin)

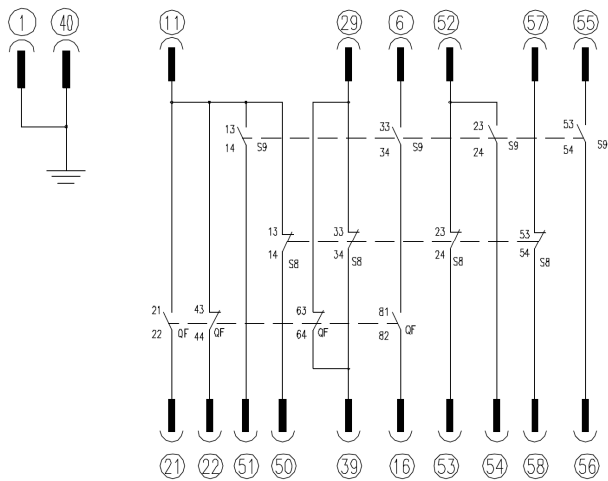
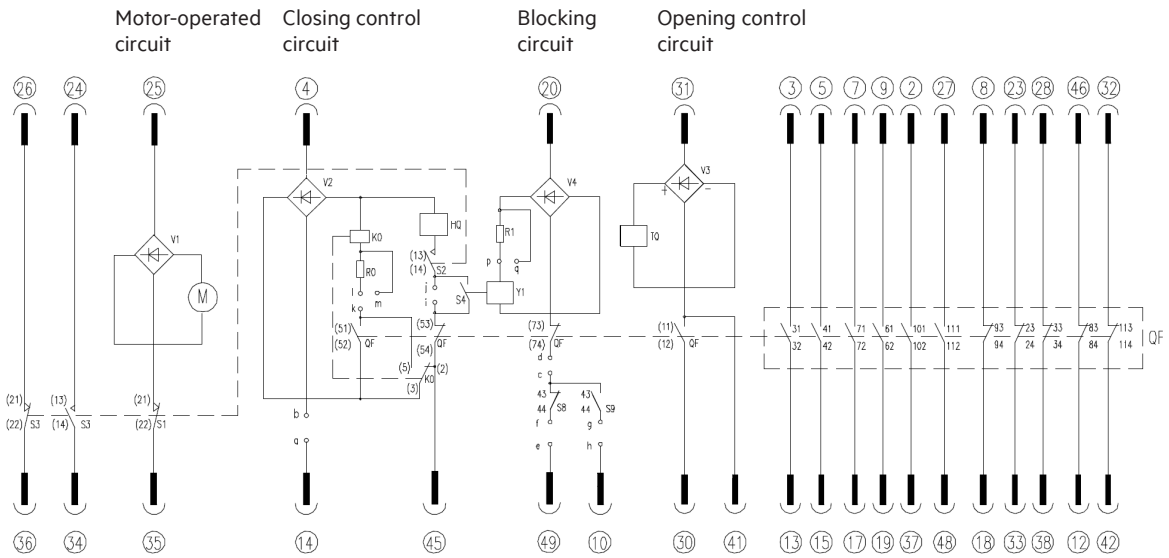

Remarks:

1. Shown with the stored-energy spring in the discharged, the breaker in open and test position;

Operating power selection:

Option	Jumper wire	p-q	m-l
	AC/DC 220V	✓	/
	AC/DC 110V	✓	✓

Note: “ / ” indicates disconnection;

“ ✓ ” indicates connect;

Optional wiring setting:

Option	Jumper wire	a-b	c-d	e-f	g-h	a-f	a-g	b-c	i-j	l-k
■ Anti-pumping relay	■ Blojng coil	✓	✓	✓	✓	/	/	/	/	✓
	□ Blojng coil	/	/	/	/	✓	✓	✓	✓	✓
□ Anti-pumping relay	■ Blojng coil	✓	✓	✓	✓	/	/	/	/	/
	□ Blojng coil	/	/	/	/	✓	✓	✓	✓	/

S9:	Limit switch	HQ:	Closing coil	V1-V4:	Rectifier
S8:	Limit switch	TQ:	Opening coil	K0:	Anti-pumping relay (Optional)
S4:	Auxiliary switch for blocking coil	RO-R1:	Resistance	Y1:	Blocking coil (Optional)
S1-S3:	Energy storage position switch	a-q:	Jumper terminal		
QF:	Auxiliary switch	M:	Energy-Storage motor		

# Selection Guide

## Withdrawable (64Pin)

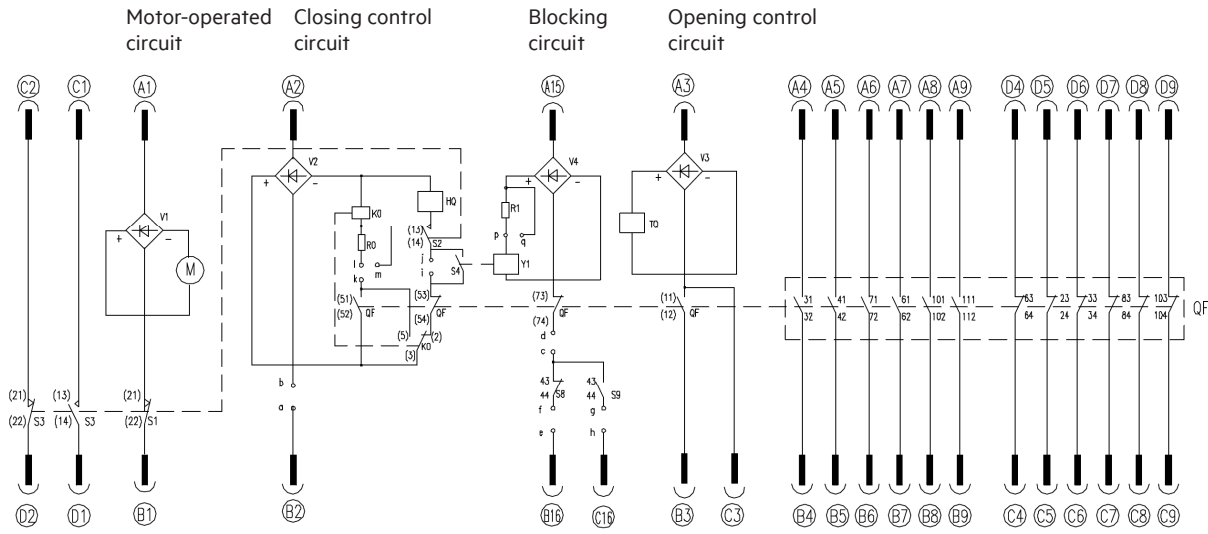

overcurrent release (A)    overcurrent release (C)    overcurrent release (B)

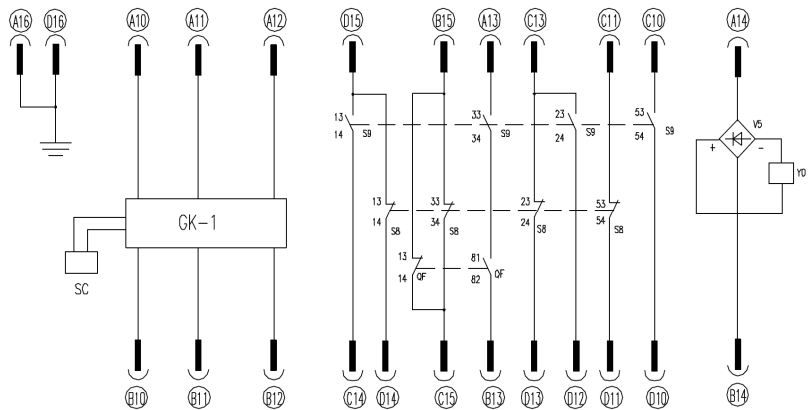

Remarks:

1. Shown with the stored-energy spring in the discharged, the breaker in open and test position;

Operating power selection:

Option	Jumper wire	p-q	m-l
AC/DC 220V		✓	/
AC/DC 110V		✓	✓

Note: “ / ” indicates disconnection;  
“ ✓ ” indicates connect;

Optional wiring setting:

Option	Jumper wire	Jumper wire								
		a-b	c-d	e-f	g-h	a-f	a-g	b-c	i-j	l-k
■ Anti-pumping rely	■ Blojcing coil	✓	✓	✓	✓	/	/	/	/	✓
	□ Blojcing coil	/	/	/	/	✓	✓	✓	✓	✓
□ Anti-pumping rely	■ Blojcing coil	✓	✓	✓	✓	/	/	/	/	/
	□ Blojcing coil	/	/	/	/	✓	✓	✓	✓	/

S9:	Limit switch	HQ:	Closing coil	V1-V4:	Rectifier
S8:	Limit switch	TQ:	Opening coil	K0:	Anti-pumping relay (Optional)
S4:	Auxiliary switch for blocking coil	RO-R1:	Resistance	Y1:	Blocking coil (Optional)
S1-S3:	Energy storage position switch	a-q:	Jumper terminal	GK-1:	Controller
QF:	Auxiliary switch	M:	Energy-Storage motor	SC:	Overcurrent trip coil (Optional)

# Ordering Check List

**SecoVac 12kV/17.5kV Ordering check list**

**Project** \_\_\_\_\_ **Product** \_\_\_\_\_

**Order Quantity** \_\_\_\_\_

**Rated voltage:**  12kV  17.5kV **Installation Mode:**  Withdrawable  Fixed

Pole type	<input type="checkbox"/> Embedded Pole		
Phase Distance	<input type="checkbox"/> 150mm	<input type="checkbox"/> 210mm	<input type="checkbox"/> 275mm
Rated current	<input type="checkbox"/> 630A  <input type="checkbox"/> 1250A	<input type="checkbox"/> 630A  <input type="checkbox"/> 1250A  <input type="checkbox"/> 1600A  <input type="checkbox"/> 2000A	<input type="checkbox"/> 1600A <input type="checkbox"/> 2000A  <input type="checkbox"/> 2500A <input type="checkbox"/> 3150A  <input type="checkbox"/> 4000A <input type="checkbox"/> 5000A
Rated short-circuit breaking current	<input type="checkbox"/> 25kA  <input type="checkbox"/> 31.5kA	<input type="checkbox"/> 25kA  <input type="checkbox"/> 31.5kA  <input type="checkbox"/> 40kA  <input type="checkbox"/> 50kA	<input type="checkbox"/> 31.5kA  <input type="checkbox"/> 40kA  <input type="checkbox"/> 50kA

Remark: Conguration of related current and short circuit breaking current please refer to the table of installation dimension

**Earthing mode:**  Earthing with copper bar at the bottom of truck  Earthing with connector on the sides of truck

**Rated operation voltage for mechanism:**  DC110V  DC220V  AC110V  AC220V

**Rated voltage for energy storing motor:**  DC110V  DC220V  AC110V  AC220V

**Secondary wiring:**  Withdrawable Method(64Pin)  Fixed Method

Withdrawable Method(58Pin)  Other Method

Closing latching electromagnet  DC110V  DC220V  AC110V  AC220V

**\*Function optional:**  Position latching electromagnet  DC110V  DC220V  AC110V  AC220V

Anti-pump relay

**\*Over current release:**  Without over current release  1over current release  2over current release  3over current release

**Standard accessory:**  Energy-stroing handle (2pcs for each 5 breakers as standard offer)  Rocking handle of chassis (2pcs for each 5 breakers as standard offer)

**Special Request:** \_\_\_\_\_

**Signature of buyer** \_\_\_\_\_ **Date** \_\_\_\_\_ / \_\_\_\_\_ / \_\_\_\_\_

\*It will have additional cost if not a standard product(except anti-pump relay).

# Ordering Check List

## SecoVac 24kV Ordering check list

**Project** \_\_\_\_\_ **Product** \_\_\_\_\_

**Order Quantity** \_\_\_\_\_

**Rated voltage:**  24kV **Installation Mode:**  Withdrawable

<b>Pole type</b>	<input checked="" type="checkbox"/> Embedded Pole					
<b>Phase Distance</b>	<input checked="" type="checkbox"/> 275mm					
<b>Rated current</b>	<input type="checkbox"/> 630A	<input type="checkbox"/> 1250A	<input type="checkbox"/> 1600A	<input type="checkbox"/> 2000A	<input type="checkbox"/> 2500A	<input type="checkbox"/> 3150A
<b>Rated short-circuit breaking current</b>	<input type="checkbox"/> 25kA	<input type="checkbox"/> 31.5kA				

Remark: Conguration of related current and short circuit breaking current please refer to the table of installation dimension

**Earthing mode:**  Earthing with copper bar at the bottom of truck  Earthing with connecter on the sides of truck

**Rated operation voltage for mechanism:**  DC110V  DC220V  AC110V  AC220V

**Rated voltage for energy storing motor:**  DC110V  DC220V  AC110V  AC220V

**Secondary wiring:**  Withdrawable Method(64Pin)  Fixed Method

Withdrawable Method(58Pin)  Other Method

Closing latching electromagnet  DC110V  DC220V  AC110V  AC220V

**\*Function optional:**  Position latching electromagnet  DC110V  DC220V  AC110V  AC220V

Anti-pump relay

**\*Over current release:**  Without over current release  1over current release  2over current release  3over current release

**Standard accessory:**  Energy-stroing handle (2pcs for each 5 breakers as standard offer)  Rocking handle of chassis (2pcs for each 5 breakers as standard offer)

**Special Request:** \_\_\_\_\_

**Signature of buyer** \_\_\_\_\_ **Date** \_\_\_\_\_ / \_\_\_\_\_ / \_\_\_\_\_

\*It will have additional cost if not a standard product(except anti-pump relay).

# Ordering Check List

## SecoVac 40.5kV Ordering check list

**Project** \_\_\_\_\_ **Product** \_\_\_\_\_

**Order Quantity** \_\_\_\_\_

**Rated voltage:**  40.5kV **Installation Mode:**  Withdrawable

<b>Pole type</b>	<input checked="" type="checkbox"/> <b>Embedded Pole</b>					
<b>Phase Distance</b>	<input checked="" type="checkbox"/> 275mm					
<b>Rated current</b>	<input type="checkbox"/> 630A	<input type="checkbox"/> 1250A	<input type="checkbox"/> 1600A	<input type="checkbox"/> 2000A	<input type="checkbox"/> 2500A	<input type="checkbox"/> 3150A
<b>Rated short-circuit breaking current</b>	<input type="checkbox"/> 25kA	<input type="checkbox"/> 31.5kA				

Remark: Conguration of related current and short circuit breaking current please refer to the table of installation dimension

**Earthing mode:**  Earthing with copper bar at the bottom of truck  Earthing with connector on the sides of truck

**Rated operation voltage for mechanism:**  DC110V  DC220V  AC110V  AC220V

**Rated voltage for energy storing motor:**  DC110V  DC220V  AC110V  AC220V

**Secondary wiring:**  Withdrawable Method(64Pin)  Fixed Method

Withdrawable Method(58Pin)  Other Method

Closing latching electromagnet  DC110V  DC220V  AC110V  AC220V

**\*Function optional:**  Position latching electromagnet  DC110V  DC220V  AC110V  AC220V

Anti-pump relay

**\*Over current release:**  Without over current release  1over current release  2over current release  3over current release

**Standard accessory:**  Energy-stroing handle (2pcs for each 5 breakers as standard offer)  Rocking handle of chassis (2pcs for each 5 breakers as standard offer)

**Special Request:** \_\_\_\_\_

**Signature of buyer** \_\_\_\_\_ **Date** \_\_\_\_\_ / \_\_\_\_\_ / \_\_\_\_\_

\*It will have additional cost if not a standard product(except anti-pump relay).

## Ordering Check List

## SecoVac 40.5kV (VCB on truck) Ordering check list

Project \_\_\_\_\_ Product \_\_\_\_\_

Order Quantity \_\_\_\_\_

Rated voltage:  40.5kVInstallation Mode:  Withdrawable

Pole type	<input checked="" type="checkbox"/> Embedded Pole					
Phase Distance	<input checked="" type="checkbox"/> 300mm					
Rated current	<input type="checkbox"/> 630A	<input type="checkbox"/> 1250A	<input type="checkbox"/> 1600A	<input type="checkbox"/> 2000A	<input type="checkbox"/> 2500A	<input type="checkbox"/> 3150A
Rated short-circuit breaking current	<input type="checkbox"/> 25kA	<input type="checkbox"/> 31.5kA				

Remark: Conguration of related current and short circuit breaking current please refer to the table of installation dimension

Earthing mode:  Earthing with copper bar at the bottom of truck  Earthing with connector on the sides of truckRated operation voltage for mechanism:  DC110V  DC220V  AC110V  AC220VRated voltage for energy storing motor:  DC110V  DC220V  AC110V  AC220VSecondary wiring:  Withdrawable Method(64Pin)  Other Method\*Function optional:  Closing latching electromagnet  DC110V  DC220V  AC110V  AC220V Anti-pump relay\*Over current release:  Without over current release  1over current release  2over current release  3over current releaseStandard accessory:  Energy-stroing handle (2pcs for each 5 breakers as standard offer)  Rocking handle of chassis (2pcs for each 5 breakers as standard offer)

Special Request: \_\_\_\_\_

Signature of buyer \_\_\_\_\_

Date \_\_\_\_\_ / \_\_\_\_\_ / \_\_\_\_\_

\*It will have additional cost if not a standard product(except anti-pump relay).

# GEIS

GEIS Electric

Website: [www.geis.tech](http://www.geis.tech)

Hotline: +86 400-820-5234

This catalog may be subjected to revision without prior notice.  
Version No.: GENCMVAA26V1

