

GEIS

Wave Cast Cast Coil Transformers

GEIS Electrical Protection

Safer Smarter Greener



About GEIS

GEIS was established in 2019 following the spin-off of several businesses and assets that ABB had acquired from GE on July 1, 2018, including 3 manufacturing centers, Warehousing & Trading business at FTZ, China Technology Center.

- Components: Full range of circuit breakers up to 40.5kV: Medium voltage vacuum circuit breakers, LV circuit breakers: ACB, MCCB, MCB, RCD, RCBO: Control components.
- Equipment: MV switchgear (Air insulation and Gas Insulation Technology), LV switchgear, switchboard.
- Medium voltage distribution transformer.
- Medium voltage ATS system (Paralleling Switchgear).

After the separation, all the above product lines were rebranded as AEG for selected markets and GEIS for global markets. Moreover, GEIS has expanded its technological portfolio to include medium-voltage controls such as VFDs and soft starters, as well as ATS systems and EV chargers.



Quality is Built-in

Where Technology Meets Manufacturing Excellence for Customers

- Since 2000, we have been specializing in localizing world-class products and manufacturing technologies, developing strong expertise and a highly capable team.
- Vertical integrated Shanghai Manufacturing Center brought key manufacturing processes into a 75,000 m² facility, enabling high-quality, high-efficiency production and fostering innovation. A dedicated R&D team committed to developing products that meet global standards and serve diverse applications.
- Global expansion: GEIS's first Thailand facility makes it easier to serve customers worldwide.



GEIS deliver complete range of products for the evolving electrification needs:



SecoVac VCB



M-PACT Plus ACB



Elfa Series MCB/RCBO



SolidDrive MV VFD



SecoGear MV Switchgear



RMU Gas Insulated Switchgear



WaveCast Transformer



MLS LV Switchgear

WaveCast Cast Coil Transformers

Catalogue

A

Product Description

- A.1 WaveCast Transformers
- A.2 Certification

B

Product Introduction

- B.1 Vacuum Cast Windings
- B.2 Winding Assembly
- B.3 Coers
- B.3 Enclosures
- B.4 Accessories
- B.5 Applicable Standards

C

Configurations

- C.1 IEC Transformer Technical Specifications
- C.5 IEEE Transformer Technical Specifications
- C.8 Enclosures Technical Specifications
- C.9 Typical Incoming and Outgoing Connections
- C.11 IP54 Enclosure
- C.12 Typical Electrical Drawings

D

Other Information

- D.1 Testing
- D.2 Packaging
- D.3 Handling & Transporting
- D.4 Foundation Installation
- D.5 Checklist

Product Description

WaveCast Cast Coil Transformers

Reliable. Efficient.

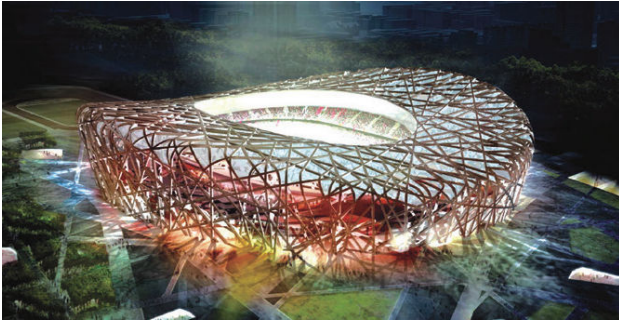

WaveCast Coil transformers from GEIS are characterized by high safety, reliability, energy-savings, and convenient maintenance. Advanced design of the winding assembly establishes superior performance to meet today's exacting needs. Indoors or outdoors, they are designed for use in the most demanding designed for use in the most demanding and diverse environments and in all and diverse environments and in all applications requiring reliable power.

Typical applications of cast coil transformers include:

- Data center
- Utility
- Industrial critical power solutions
- New energy, Wind, solar
- Steel mills, Chemical plants
- Offshore drilling platform
- Pulp & paper mills
- Cement & mining operations
- Automotive industry
- Commercial buildings, hospitals, universities, residential areas



Product Description

Certification

GEIS has passed the entire routine and type test carried out by third party laboratories, such as KEMA, CTQC (China). The test approvals include C2 climate class, E2 environment class, F1 fire behavior grade, 5S short-circuit capability, typical lightning impulse and temperature rise test.



Cast coil transformers have several advantages over alternative transformer technologies.

- **Environmental safety.** It is understood that cast resin transformers provide enhanced safety as they are free from flammable oil insulation. For this reason, it is widely used in urban power grids, commercial buildings, hospitals and universities among other applications.
- **High capability of short-circuit withstand.** Because of the strong protection provided by the vacuum cast epoxy encapsulated coils, Wave Cast transformers are stronger than either liquid-filled or ventilated dry-type transformers. Short circuit tests have proven this strength well beyond IEC and ANSI requirements. GEIS designs and manufactures its cast coils to be among the strongest in the industry.
- **Impervious to adverse atmospheric conditions.** Unlike ventilated dry-type transformers and in a manner similar to liquid-filled transformers, Wave cast coil transformers are optimal for use in harsh environments. The epoxy casting is extremely inert and renders the windings impervious to moisture, dirt and corrosive elements.



- **Suitability for simple indoor installation and convenient maintenance.** Unlike the case with liquid-filled transformers, indoor installations do not require an automatic fire extinguishing system or fire vault, oil checking or replacing, or a liquid confinement area. This benefits long term maintenance.
- **Extended ratings.** Wave cast coil transformers can be provided with the highest self-cooled and fan-cooled extended ratings of any transformers in their size class.
- **High efficiency.** Wave Cast transformers boast high efficiency stemming from the technical specification. With low no-load loss and load loss, there are energy savings as well as total ownership cost (TOC) savings.

Vacuum Cast Windings

Tough epoxy provides



WaveCast vacuum cast windings are highly engineered components requiring specific expertise in electrical, material, thermal and mechanical engineering. The process of measuring, mixing, heating and vacuum casting materials into the windings is equally critical.

Cast coils are solid vacuum cast with epoxy resin compound. The epoxy is applied under vacuum to hermetically seal the windings in a highly durable epoxy. Quartz filler is included, which provides increased viscosity to the resin, better impregnation and increased capability to withstand short circuits. The epoxy mixture is carefully designed to provide maximum strength and environmental protection and yet minimize the temperature differential through the coil thickness.

Process control ensures that the coils are void-free and prevents partial discharges within the resin material; or cracking of the epoxy over a wide range of ambient and operating temperatures.

The principal advantage of solid vacuum cast construction is that the cast coil seals out harmful fumes, air and moisture, preventing them from entering the windings. The solid cast transformer achieves a maximum degree of resin impregnation during the casting process.

Other advantages of vacuum cast construction include:

- **Dielectric strength** - Windings are corona-free at twice the rated voltage.
- **Mechanical strength** - Short circuit capability meets and exceeds the requirements of IEC60076-11:2004 and IEEE standard C57.12.91-2001.
- **Thermal strength** - Withstands fluctuating operating temperatures ranging from -40°C to 180°C without damage to the epoxy insulation.
- **Insulation system** - Tested to ANSI/NEMA and IEC standards, turn-by-turn and layer-by-layer electrical insulation components (polyimide film) are recognized at 180°C .



Product Introduction

Winding Assembly

Advanced total foil strip technology.

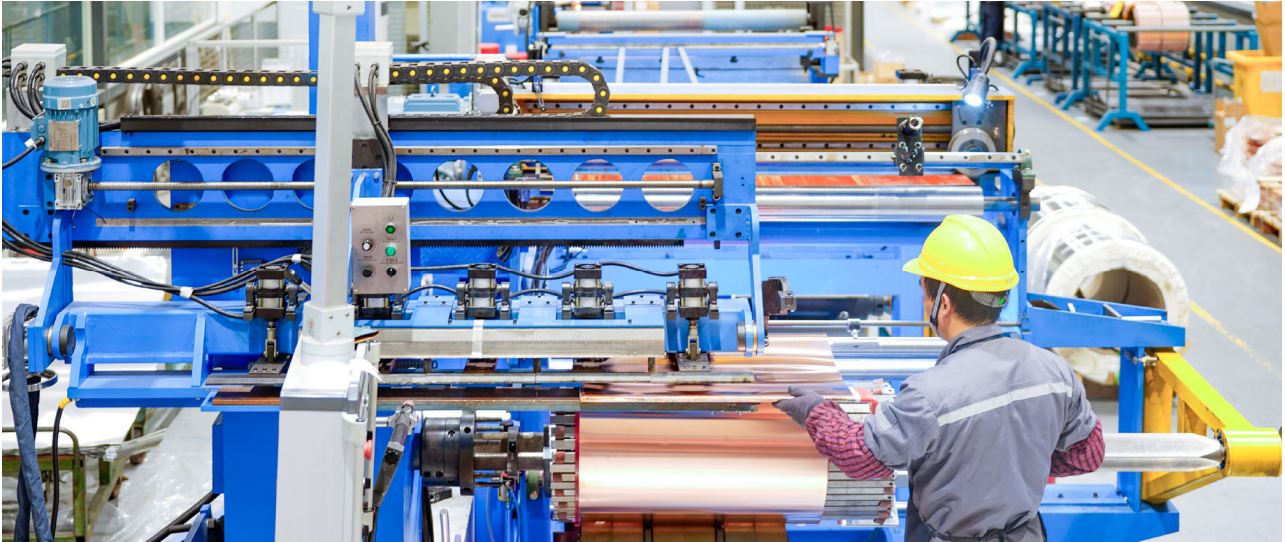

Both high- and low-voltage wind-ings are made of copper foil or foil strip and vacuum cast in metal molds as separate concentric cylinders.

High-voltage windings are wound using foil strip technology. Multiple layers of polyimide film (180°C system) or DUPONT @MYLAR (155°C system) provide turn insulation. Individual coil sections are wound directly on the inner winding mold and then connected in series by welding. External molds are assembled and placed in a vacuum chamber. Coils are pre-heated under high vacuum to remove trapped moisture. A special mixture of epoxy resin and quartz powder flows into the mold through an opening in the molding assembly. After pouring, the into the mold thrmolds are cured in a time-temperatureough an opening in the process controlled oven. The result is a reliable, vacuum cast winding with an unusually high strength, an essentially void free assembly capable of withstanding high electrical stress.

Low-voltage windings use foil conductor construction. A fiberglass mesh provides support for the inside of the windings. Full-width sheet conductor that has SCC layer insulation is wound onto the cylinder. Start and finish lead bars are TIG welded to the foil conductor. Low-voltage windings are also vacuum cast in a metal mold using the same technique as the high-voltage windings.

Why do we use foil strip windings? They are used to reduce the electrical field density between layers. For example, the typical layer electrical field density of 1000KVA/10/0.4kV transformer (made of copper wire) is 2kV/mm, while the typical value for foil windings it is 0.3kV/mm. The capability to withstand over-voltage, such as lightning pulse and power, power frequency withstand voltage, are greatly improved.

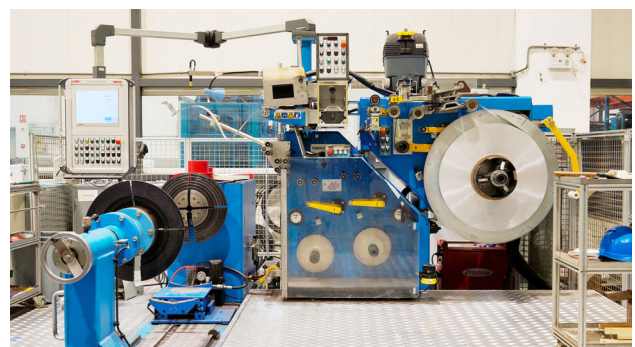

Product Introduction

Cores

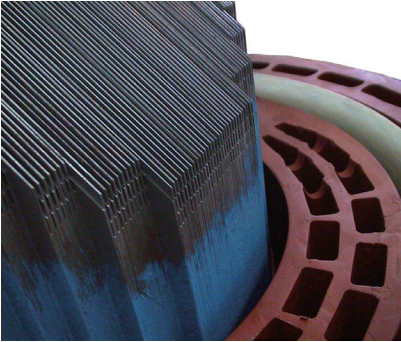

Construction ensures optimal performance.

Transformer cores utilize mitered step-lap technology to optimize performance and minimize sound levels. Cores are constructed of non-aging, high permeability, grain-oriented silicon steel laminations without punched holes, offering high magnetic permeability.

Core laminations are free of burrs and stCoracked wite laminations about gaps, resulting in the lowest possible losses from magnetic hysteresis and eddy currents. The core clamping brackets are designed to provide an even distribution of clamping forces to the core yokes and legs, and are rigidly braced to reduce sound levels and losses. Other core construction benefits include:

- Magnetic flux densities, kept well below saturation point
- Surfaces of the core, clamps and tie saturation point rods are all treated against orrosion

Enclosures



Withstands the harshest indoor and outdoor environments.

Enclosures are suitable for lifting, jacking, rolling or skidding with provisions for lifting the transformer from its base. The lifting the transformer from its base. The standard indoor enclosures are from IP20 to IP54 and NEMA 1, Category C construction.

While core and coil technologies have been enhanced to combat caustic and humid environments, Wave Cast transformers are further protected by properly designed enclosures. GEIS enclosures are custom fabricated using heavy gauge sheet steel. Optional aluminum and stainless steel enclosures are available.

Additional protection against harsh outdoor or indoor environments is provided through electrostatically deposited dry powder paint baked onto a phosphate treated surface. The paint finish is neat, clean and highly resistant to corrosion.

A variety of optional enclosures is available: drip proof roofs, supplemental filters, screens, hinged panels and special hardware. Other modifications can also be made to extend the enclosure, add bottom plates, add end sheets and/or include special cutouts for specific applications.

Product Introduction

Accessories

Temperature monitor and fan controller

The controller can display the operating temperature of windings, start and shut off the cooling fans and provides alarm/trip signal (normal open voltage-free contact), ensuring effective monitoring and protection of the transformer.

The PT100 sensors are inserted into each LV winding to transmit temperature signals, which can be displayed on the controller panel.

Main functionality:

- Set alarms and trip temperature levels
- Record the maximum temperature in non-volatile memory
- Send audible over-temperature alarm, alarm signal and trip signal
- Start and stop fans automatically or manually
- Provide communication interface (optional)



BWD-3K series temperature controller

Models	Functions
BWD-3K130	Cyclic Display Temperature, Auto Control Fan, Over Temperature Alarm, Auto-Power-cut (Trip). Sensor Disorder Alarm
BWD-3K130A	Share the functions of BWD-3K130 and Equipped with RS232 or RS232 or RS485 Interfaces that outputs the Temperature, Fan States and Sensor States
BWD-3K130B	Share the functions of BWD-3K130 and Provide the outputs of three 4-20mA Analog Currents or 1-5V Analog Voltages correspond to three temperature values
BWD-3K130AB	Have the functions of both BWD-3K130A and BWD-3K130B

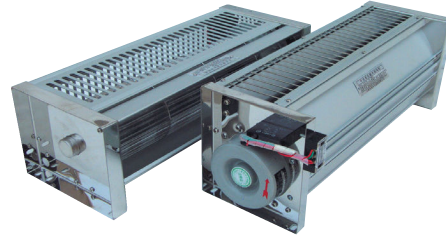

Cross flow fan

The low noise cross flow fan reduces the winding temperature, enhances the overload ability, and prolongs the service life of the transformer.

The rated power can be increased by 25-40% when forced air-cooling is used.

Rollers

Four rollers can be equipped under a transformer or enclosure to facilitate moving in two directions.



Enclosures

Wavecast coil transformer enclosures are available to meet or exceed IP20/IP21/IP23/IP30/IP31/IP33/IP40/IP41/IP43 and IP54 enclosure requirements typical for indoor or outdoor usage.

Applicable Standards

IEC Transform

IEC 60076-1 Power transformers - Part 1: General

IEC 60076-2 Power transformers - Part 2: Temperature rise

IEC 60076-3 Power transformers - Part 3: Insulation levels, dielectric tests and external clearances in air

IEC 60076-4 Power transformers - Part 4: Guide to lightning impulse and switching impulse testing - Power transformers and reactors

IEC 60076-5 Power transformers - Part 5: Ability to withstand short-circuit

IEC 60076-8 Power transformers - Part 8: Application guide

IEC 60076-10 Power transformers - Part 10: Determination of sound levels

IEC 60076-10-1 Power transformers - Part 10-1: Determination of transformer and reactor sound levels - User guide

IEC 60076-11 Power transformers - Part 11: Dry-type transformers

IEC 60076-12 Power transformers - Part 12: Loading guide for dry-type power transformers

IEEE Transformer

IEEE Std C57.12.01 IEEE Standard General Requirements for Dry-Type Distribution and Power Transformers, Including Those with Solid-Cast and/or Resin Encapsulated Windings

IEEE Std C57.12.91 IEEE Standard Test Code for Dry-Type Distribution and Power Transformers

Configurations

IEC Transformer Technical Specifications

General data

Conductors	Copper or Aluminum
Frequency (Hz)	50
Off-load tapping range	±2x2.5%, ±5%
Insulation class	F(155°C) or H (180°C)
Temperature rise	100K(F) or 125K(H)
Ambient temperature (°C)	Max. 40, Min. -25
Altitude (m above sea level)	≤1,000
Connection	Dyn5, Dyn11
Cooling	AN, AN/AF
Voltage fluctuation	±5%

General data

Highest voltage for equipment U_m (r.m.s)	Rated short duration separate source AC withstand voltage (r.m.s)	Rated lightning impulse withstand voltage (peak value)
kV	kV	kV
≤1.1	3	-
3.6	10	40
7.2	20	60
12	28	75
17.5	38	95
24	50	125
36	70	170

Optional Accessories (indicated on Checklist, page D.5)

- Protective enclosures (GBN series)
- Fans for AF rating
- Rollers for temporary moving on site
- Zero current transformers
- Surge arresters
- Bar fuse for controller wiring from LV terminal
- Space heaters & thermostat for space heaters
- Lighting
- Limit switch for enclosure doors
- Electromagnetic lock for enclosure door Flexible connector

Special service conditions should be clearly stated

- Coastal areas
- Offshore installations
- High harmonic wave
- Used for convertors
- Used for rectifier circuitsconnector

IEC Transformer Technical Specifications

Typical outline for IP00 transformer

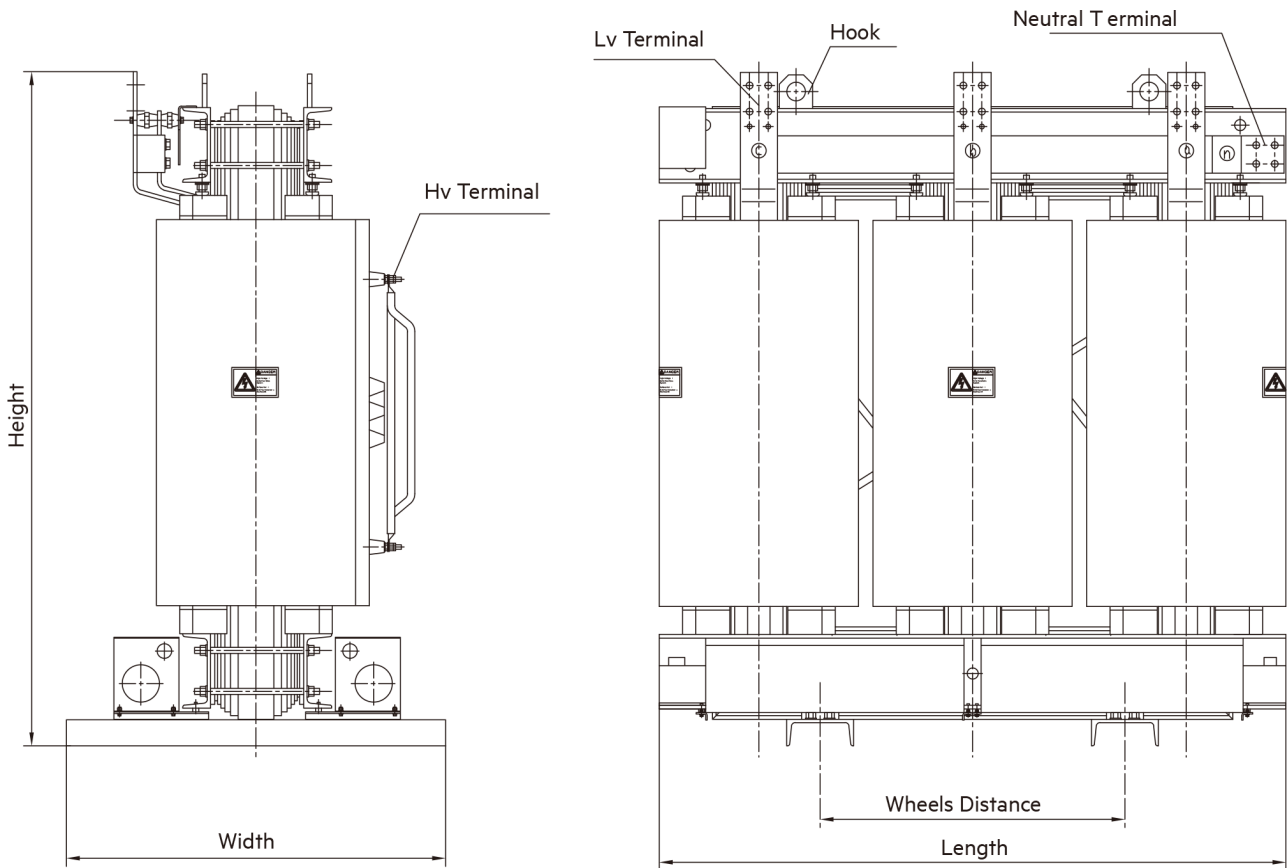

Configurations

IEC Transformer Technical Specifications

Voltage class 12 kV, copper windings

Rated Power	kVA	250	315	400	500	630	800	1000	1250	1600	2000	2500
High-voltage	kA	10,11										
Tapping Range	/	±2×2.5%, ±3×2.5%, ±4×2.5%, ±5%										
Low-Voltage	V	400, 415, 433										
Frequency	Hz	50										
Vector Group	/	Dyn11, Dyn5, YNyn0, YNd5*										
No-load Loss	W	730	890	990	1180	1350	1500	1800	2100	2450	3100	3600
Load Loss 75°C	W	2400	2990	3520	4250	5300	6100	7110	8500	10400	12800	15400
Load Loss 120°C	W	2780	3400	4000	4900	6000	7000	8180	9750	12000	14400	17000
Short-circuit Impedance	%	4	4	4	4	6	6	6	6	6	6	6
Noise LPA	dB	46	46	46	48	48	50	50	50	52	54	56
Length	mm	1200	1230	1260	1310	1460	1470	1500	1580	1760	1850	2010
Width	mm	750	750	750	750	750	920	920	920	920	920	1170
Height	mm	970	1040	1110	1160	1170	1280	1400	1440	1510	1670	1740
Weight	kg	1200	1330	1500	1750	2010	2310	2710	3190	4060	4870	5600
Distance Between Rollers	mm	660	660	660	660	660	820	820	820	820	820	1070

Voltage class 12 kV, aluminum windings

Rated Power	kVA	250	315	400	500	630	800	1000	1250	1600	2000	2500
High-voltage	kA	10,11										
Tapping Range	/	±2×2.5%, ±3×2.5%, ±4×2.5%, ±5%										
Low-Voltage	V	400,415,433										
Frequency	Hz	50										
Vector Group	/	Dyn11, Dyn5, YNyn0, YNd5*										
No-load Loss	W	730	890	990	1180	1350	1500	1800	2100	2450	3100	3600
Load Loss 75°C	W	2400	2990	3520	4250	5300	6100	7110	8500	10400	12800	15400
Load Loss 120°C	W	2780	3400	4000	4900	6000	7000	8180	9750	12000	14400	17000
Short-circuit Impedance	%	4	4	4	4	6	6	6	6	6	6	6
Noise LPA	dB	46	46	46	48	48	50	50	50	52	54	56
Length	mm	1250	1310	1320	1350	1520	1560	1610	1680	1740	1860	2070
Width	mm	750	750	750	750	750	920	920	920	920	920	1170
Height	mm	1050	1090	1200	1300	1300	1380	1540	1640	1810	1840	1890
Weight	kg	1100	1280	1490	1680	1850	2190	2560	3050	3750	4300	5500
Distance Between Rollers	mm	660	660	660	660	660	820	820	820	820	820	1070

Voltage class 24 kV, copper windings

Rated Power	kVA	250	315	400	500	630	800	1000	1250	1600	2000	
High-voltage	kA	20, 22										
Tapping Range	/	±2×2.5%, ±3×2.5%, ±4×2.5%, ±5%										
Low-Voltage	V	400, 415, 433										
Frequency	Hz	50										
Vector Group	/	Dyn11, Dyn5, YNyn0, YNd5*										
No-load Loss	W	970	1150	1350	1530	1750	2070	2400	2790	3240	3870	
Load Loss 75°C	W	3300	4200	5040	5950	7190	8500	10050	12050	14250	18500	
Load Loss 120°C	W	3800	4850	5790	6840	8260	9780	11500	13870	16400	21280	
Short-circuit Impedance	%	6	6	6	6	6	6	6	6	6	6	
Noise LPA	dB	46	46	48	48	50	50	50	52	54	54	
Length	mm	1270	1350	1440	1470	1540	1620	1710	1850	1980	2100	
Width	mm	750	750	750	920	920	920	920	920	1170	1170	
Height	mm	1230	1300	1380	1440	1520	1610	1700	1750	1800	1900	
Weight	kg	1350	1600	1900	2200	2600	3050	3600	4500	5400	6400	
Distance Between Rollers	mm	660	660	660	820	820	820	820	820	1070	1070	

Voltage class 24 kV, aluminum windings

Rated Power	kVA	250	315	400	500	630	800	1000	1250	1600	2000	
High-voltage	kA	20, 22										
Tapping Range	/	±2×2.5%, ±3×2.5%, ±4×2.5%, ±5%										
Low-Voltage	V	400, 415, 433										
Frequency	Hz	50										
Vector Group	/	Dyn11, Dyn5, YNyn0, YNd5*										
No-load Loss	W	970	1150	1350	1530	1750	2070	2400	2790	3240	3870	
Load Loss 75°C	W	3300	4200	5040	5950	7190	8500	10050	12050	14250	18500	
Load Loss 120°C	W	3800	4850	5790	6840	8260	9780	11500	13870	16400	21280	
Short-circuit Impedance	%	6	6	6	6	6	6	6	6	6	6	
Noise LPA	dB	46	46	48	48	50	50	50	52	54	54	
Length	mm	1440	1500	1580	1600	1650	1680	1770	1890	1890	2040	
Width	mm	750	750	750	920	920	920	920	920	1170	1170	
Height	mm	1270	1360	1500	1540	1720	1740	1750	1840	1900	2040	
Weight	kg	200	1450	1850	1980	2410	2560	3130	3970	4780	5450	
Distance Between Rollers	mm	660	660	660	820	820	820	820	820	1070	1070	

*Special order, please contact GEIS.

IEC Transformer Technical Specifications

Voltage class 40.5 kV, copper windings

Rated Power	kVA	400	500	630	800	1000	1250	1600	2000	2500
High-voltage	kA	33, 35								
Tapping Range	/	±2×2.5%, ±3×2.5%, ±4×2.5%, ±5%								
Low-Voltage	V	400, 415, 433								
Frequency	Hz	50								
Vector Group	/	Dyn11, Dyn5, YNyn0, YNd5*								
No-load Loss	W	1370	1620	1860	2160	2430	2830	3240	3280	4450
Load Loss 75°C	W	4700	5780	6690	7930	9090	11000	13500	15870	19000
Load Loss 120°C	W	5400	6650	7690	9120	10450	12730	15500	18240	21850
Short-circuit Impedance	%	6	6	6	6	6	6	6	6	6
Noise LPA	dB	48	48	48	50	50	50	52	54	56
Length	mm	1520	1540	1590	1640	1770	1850	1950	1960	2140
Width	mm	920	920	920	920	920	920	920	1270	1270
Height	mm	530	1650	1710	1740	1800	1820	1900	2040	2170
Weight	kg	1750	2000	2550	2900	3400	4100	5000	5580	6600
Distance Between Rollers	mm	820	820	820	820	820	820	820	1070	1070

Voltage class 40.5 kV, aluminum windings

Rated Power	kVA	400	500	630	800	1000	1250	1600	2000	2500
High-voltage	kA	33, 35								
Tapping Range	/	±2×2.5%, ±3×2.5%, ±4×2.5%, ±5%								
Low-Voltage	V	400, 415, 433								
Frequency	Hz	50								
Vector Group	/	Dyn11, Dyn5, YNyn0, YNd5*								
No-load Loss	W	1370	1620	1860	2160	2430	2830	3240	3840	4450
Load Loss 75°C	W	4700	5780	6690	7930	9090	11000	13500	15870	19000
Load Loss 120°C	W	5400	6650	7690	9120	10450	12730	15500	18240	21850
Short-circuit Impedance	%	6	6	6	6	6	6	6	6	6
Noise LPA	dB	48	48	48	50	50	50	52	54	56
Length	mm	1740	1760	1760	1770	1820	1890	2010	2090	2150
Width	mm	920	920	920	920	920	920	920	1270	1270
Height	mm	1450	1650	1740	1830	1850	1890	1900	2080	2190
Weight	kg	1900	2200	2400	2700	3100	3600	4200	5200	6000
Distance Between Rollers	mm	820	820	820	820	820	820	820	1070	1070

Voltage class 40.5 kV, aluminum windings

Rated Power	kVA	1000	1250	1600	2000	2500	3150	4000	5000	6300	8000	10000
High-voltage	kA	33, 35										
Tapping Range	/	±2×2.5%, ±3×2.5%, ±4×2.5%, ±5%										
Low-Voltage	V	400, 415, 433										
Frequency	Hz	50										
Vector Group	/	Dyn11, Dyn5, YNyn0, YNd5*										
No-load Loss	W	2700	3130	3700	4230	4860	6000	7000	8300	9900	11300	12800
Load Loss 75°C	W	9500	11240	13450	15800	18900	21300	25600	30500	35500	40000	48000
Load Loss 120°C	W	10900	12900	15500	18240	21800	24500	29500	34900	30900	46000	55000
Short-circuit Impedance	%	6	6	6	7	7	8	8	8	8	9	9
Noise LPA	dB	53	54	55	55	55	58	62	63	63	65	65
Length	mm	1890	2010	2130	2190	2310	2430	2500	2760	2850	3000	3150
Width	mm	920	920	920	1270	1270	1270	1270	1670	1675	1675	1675
Height	mm	1700	1800	1900	1960	2050	2130	2260	2300	2550	2740	2900
Weight	kg	3600	4300	5100	5900	7000	7800	9200	11500	13200	16000	19000
Distance Between Rollers	mm	820	820	820	1070	1070	1070	1475	1475	1475	1475 2040(L)	1475 2040(L)

*Special order, please contact GEIS.

Configurations

IEEE Transformer Technical Specifications

General data

Conductors	Copper or Aluminum
Frequency (Hz)	60
Off-load tapping range	±2x2.5%, ±5%
Insulation class	F(155°C) or H (180°C)
Temperature rise	100K(F) or 115K(H)
Ambient temperature (°C)	Max. 40, Min. -25
Altitude (m above sea level)	≤1,000
Connection	Dyn5, Dyn11
Cooling	AA, AA/FA
Voltage fluctuation	±5%

Standard insulation level

Nominal Voltage	Low-frequency voltage insulation levels (r.m.s)	Basic lightning impulse insulation level (crest)
kV	kV	kV
1.2	4	10
2.5	10	20
5	12	30
8.7	19	45
15	34	95
25	50	110
34.5	70	150

Optional Accessories (indicated on Checklist, page D.5)

- Protective enclosure (GBN series)
- Fans for AF rating
- Rollers for temporary moving on site
- Zero current transformers
- Surge arresters
- Bar fuse for controller wiring from LV terminal
- Space heaters & thermostat for space heaters
- Lighting
- Limit switch for enclosure doors
- Electromagnetic lock for enclosure door
- Flexible connector

Special service conditions should be clearly stated

- Coastal areas
- Offshore installations
- High harmonic content
- Used for convertors
- Used for rectifier circuits

IEEE Transformer Technical Specifications

Voltage class 15 kV, copper windings

Rated Power	kVA	225	300	400	500	630	750	1000	1250	1500	2000	2500
High-voltage	kA	13.2, 13.8										
Tapping Range	/	$\pm 2 \times 2.5\%$, $\pm 3 \times 2.5\%$, $\pm 4 \times 2.5\%$, $\pm 5\%$										
Low-Voltage	V	220, 400, 480										
Frequency	Hz	60										
Vector Group	/	Dyn11, Dyn5, YNyn0, YNd5*										
No-load Loss	W	1100	1300	1450	1600	1700	1850	2000	2400	3000	3400	4100
Load Loss 75°C	W	1920	2500	3150	3750	4600	5700	6500	7300	9570	12200	15200
Load Loss 120°C	W	2200	2800	3650	4300	5300	6400	7500	8400	11000	14100	17500
Short-circuit Impedance	%	4	4	4	4	6	6	6	6	6	6	6
Noise LPA	dB	46	46	46	48	48	50	50	50	52	54	56
Length	mm	1220	1290	1310	1320	1470	1470	1520	1590	1710	1770	1850
Width	mm	750	750	750	750	750	920	920	920	920	920	1170
Height	mm	970	1050	1110	1180	1170	1280	1360	1430	1540	1550	1640
Weight	kg	1010	1250	1450	1650	1920	1200	2600	3150	3750	4200	5000
Distance Between Rollers	mm	660	660	660	660	660	820	820	820	820	820	1070

Voltage class 15 kV, aluminum windings

Rated Power	kVA	225	300	400	500	630	750	1000	1250	1500	2000	2500
High-voltage	kA	13.2, 13.8										
Tapping Range	/	$\pm 2 \times 2.5\%$, $\pm 3 \times 2.5\%$, $\pm 4 \times 2.5\%$, $\pm 5\%$										
Low-Voltage	V	220, 400, 480										
Frequency	Hz	60										
Vector Group	/	Dyn11, Dyn5, YNyn0, YNd5*										
No-load Loss	W	1100	1300	1450	1600	1700	1850	2000	2400	3000	3400	4100
Load Loss 75°C	W	1920	2500	3150	3750	4600	5700	6500	7300	9570	12200	15200
Load Loss 120°C	W	2200	2800	3650	4300	5300	6400	7500	8400	11000	14100	17500
Short-circuit Impedance	%	4	4	4	4	6	6	6	6	6	6	6
Noise LPA	dB	46	46	46	48	48	50	50	50	52	54	56
Length	mm	1260	1310	1320	1400	1560	1580	1670	1710	1760	1790	1890
Width	mm	750	750	750	750	750	920	920	920	920	920	1170
Height	mm	1170	1210	1220	1340	1350	1380	1540	1680	1750	1770	1800
Weight	kg	950	1150	1300	1550	1800	2000	2300	2800	3500	3800	4600
Distance Between Rollers	mm	660	660	660	660	660	820	820	820	820	820	1070

Voltage class 25 kV, copper windings

Rated Power	kVA	225	300	400	500	630	750	1000	1250	1500	2000	2500
High-voltage	kA	23										
Tapping Range	/	$\pm 2 \times 2.5\%$, $\pm 3 \times 2.5\%$, $\pm 4 \times 2.5\%$, $\pm 5\%$										
Low-Voltage	V	220, 480										
Frequency	Hz	60										
Vector Group	/	Dyn11, Dyn5, YNyn0, YNd5*										
No-load Loss	W	950	1000	1300	1500	1750	2000	2300	2600	2900	3800	4600
Load Loss 75°C	W	2900	3750	4350	4900	5650	6300	7400	9570	10900	12600	14500
Load Loss 120°C	W	3350	4300	5000	5600	6500	7300	8500	11000	12500	14500	16500
Short-circuit Impedance	%	6	6	6	6	6	6	6	6	6	6	6
Noise LPA	dB	46	46	46	48	48	50	50	50	52	54	56
Length	mm	1250	1280	1310	1410	1470	1580	1590	1620	1670	1830	2000
Width	mm	750	750	750	750	920	920	920	920	920	1170	1170
Height	mm	1190	1240	1290	1350	1390	1420	1610	1650	1700	1760	1820
Weight	kg	900	1100	1450	1650	1900	2400	2900	3100	3600	4700	5700
Distance Between Rollers	mm	660	660	660	660	820	820	820	820	820	1070	1070

*Special order, please contact GEIS.

Configurations

IEEE Transformer Technical Specifications

Voltage class 25 kV, aluminum windings

Rated Power	kVA	225	300	400	500	630	750	1000	1250	1500	2000	2500
High-voltage	kA	23										
Tapping Range	/	$\pm 2 \times 2.5\%$, $\pm 3 \times 2.5\%$, $\pm 4 \times 2.5\%$, $\pm 5\%$										
Low-Voltage	V	220, 480										
Frequency	Hz	60										
Vector Group	/	Dyn11, Dyn5, YNyn0, YNd5*										
No-load Loss	W	950	1200	1300	1500	1750	2000	2400	2800	3400	4200	5000
Load Loss 75°C	W	1950	2170	3480	4900	5650	6350	6790	7830	10100	11750	12600
Load Loss 120°C	W	2200	2500	4000	5600	6500	7300	7800	9000	11600	13500	14500
Short-circuit Impedance	%	6	6	6	6	6	6	6	6	6	6	6
Noise LPA	dB	46	46	46	48	48	50	50	50	52	54	56
Length	mm	1430	1490	1500	1530	1570	1590	1650	1790	1830	1980	2040
Width	mm	750	750	750	750	920	920	920	920	920	1170	1170
Height	mm	1320	1340	1360	1410	1480	1520	1680	1690	1820	1840	1980
Weight	kg	1050	1250	1350	1600	1750	2100	2550	3000	3400	4450	5400
Distance Between Rollers	mm	660	660	660	660	820	820	820	820	820	1070	1070

Voltage class 34.5 kV, copper windings

Rated Power	kVA	500	630	750	1000	1250	1500	2000	2500
High-voltage	kA	34.5							
Tapping Range	/	$\pm 2 \times 2.5\%$, $\pm 3 \times 2.5\%$, $\pm 4 \times 2.5\%$, $\pm 5\%$							
Low-Voltage	V	400, 480							
Frequency	Hz	60							
Vector Group	/	Dyn11, Dyn5, YNyn0, YNd5*							
No-load Loss	W	1800	2300	2500	2800	3300	4000	4600	5400
Load Loss 75°C	W	4350	5400	6090	8250	9570	11300	12650	14350
Load Loss 120°C	W	5000	6200	7000	9500	11000	13000	14500	16500
Short-circuit Impedance	%	6	6	6	6	6	6	6	6
Noise LPA	dB	48	48	50	50	50	52	54	56
Length	mm	1530	1690	1740	1770	1820	1880	1940	2060
Width	mm	920	920	920	920	920	920	1270	1270
Height	mm	1620	1630	1640	1730	1820	1840	1930	1940
Weight	kg	2100	2400	2680	3000	3600	4300	5000	6050
Distance Between Rollers	mm	660	820	820	820	820	820	1070	1070

Voltage class 34.5 kV, aluminum windings

Rated Power	kVA	500	630	750	1000	1250	1500	2000	2500
High-voltage	kA	34.5							
Tapping Range	/	$\pm 2 \times 2.5\%$, $\pm 3 \times 2.5\%$, $\pm 4 \times 2.5\%$, $\pm 5\%$							
Low-Voltage	V	400, 480							
Frequency	Hz	60							
Vector Group	/	Dyn11, Dyn5, YNyn0, YNd5*							
No-load Loss	W	2000	2100	2500	2800	3300	4200	5000	5400
Load Loss 75°C	W	3150	4780	6090	7400	9570	11300	12650	14350
Load Loss 120°C	W	3600	5500	7000	8500	11000	13000	14500	16500
Short-circuit Impedance	%	6	6	6	6	6	6	6	6
Noise LPA	dB	48	48	50	50	50	52	54	56
Length	mm	1770	1800	1810	1820	1880	1980	2130	2150
Width	mm	920	920	920	920	920	920	1270	1270
Height	mm	1550	1720	1750	1780	1850	1930	1950	2170
Weight	kg	2000	2100	2500	2900	3400	4000	4900	5500
Distance Between Rollers	mm	820	820	820	820	820	820	1070	1070

*Special order, please contact GEIS.

Enclosures Technical Specifications**10kV, 11kV, 13.2kV, 13.8kV Enclosure**

Enclosure Nominal Dimensions(mm)						
kVA	Cable entry or bar top entry			Bar side entry		
	Height	Width	Depth	Height	Width	Depth
160	2200	1600	1200	2200	1800	1200
200	2200	1600	1200	2200	1800	1200
250	2200	1600	1200	2200	1800	1200
315	2200	1600	1200	2200	1800	1200
400	2200	1600	1200	2200	1800	1200
500	2200	1600	1200	2200	1800	1200
630	2200	1800	1400	2200	2000	1400
800	2200	1800	1400	2200	2000	1400
1000	2200	2000	1400	2200	2200	1400
1250	2200	2000	1400	2200	2200	1400
1600	2200	2200	1400	2200	2400	1400
2000	2200	2400	1600	2200	2400	1600
2500	2200	2400	1600	2200	2600	1600
3150	2400	2600	1600	2400	2600	1600

20kV, 22kV, 23kV Enclosure

Enclosure Nominal Dimensions(mm)						
kVA	Cable entry or bar top entry			Bar side entry		
	Height	Width	Depth	Height	Width	Depth
315	2200	1800	1400	2200	2000	1400
400	2200	1800	1400	2200	2000	1400
500	2200	2000	1400	2200	2000	1400
630	2200	2000	1600	2200	2200	1600
800	2200	2000	1600	2200	2200	1600
1000	2200	2200	1600	2200	2400	1600
1250	2200	2200	1600	2200	2400	1600
1600	2400	2400	1600	2400	2400	1600
2000	2400	2600	1800	2400	2600	1800
2500	2400	2600	1800	2400	2600	1800
3150	2600	2800	1800	2600	2800	1800

33kV, 34.5kV, 35kV Enclosure

Enclosure Nominal Dimensions(mm)						
kVA	Cable entry or bar top entry			Bar side entry		
	Height	Width	Depth	Height	Width	Depth
630	2200	2400	1800	2200	2400	1800
800	2200	2400	1800	2200	2400	1800
1000	2400	2600	1800	2400	2600	1800
1250	2400	2600	1800	2400	2600	1800
1600	2600	2800	1800	2600	2800	1800
2000	2600	2800	2000	2600	2800	2000
2500	2600	3000	2000	2600	3000	2000
3150	2800	3000	2000	2800	3000	2000
4000	2800	3200	2400	2800	3200	2400
5000	3000	3600	2400	3000	3600	2400
6300	3200	3600	2400	3200	3600	2400
8000	3400	3800	2400	3400	3800	2400
10000	3600	3800	2400	3600	3800	2400

Configurations

Typical Incoming and Outgoing Connections

Cable incoming and outgoing from the top or bottom

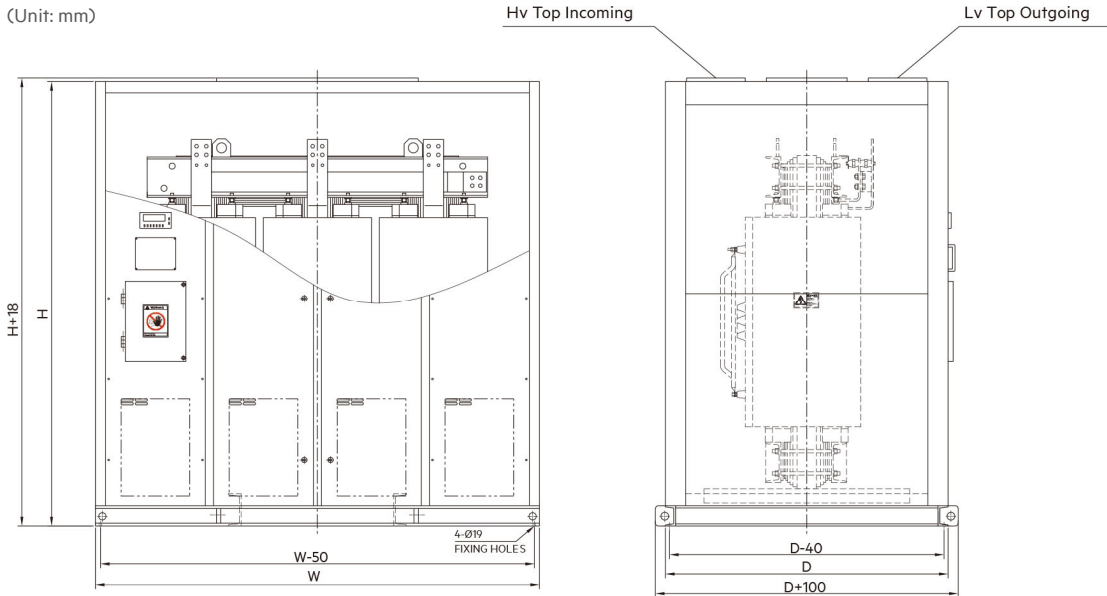

Cable incoming from the top or bottom and bus bar outgoing from the top

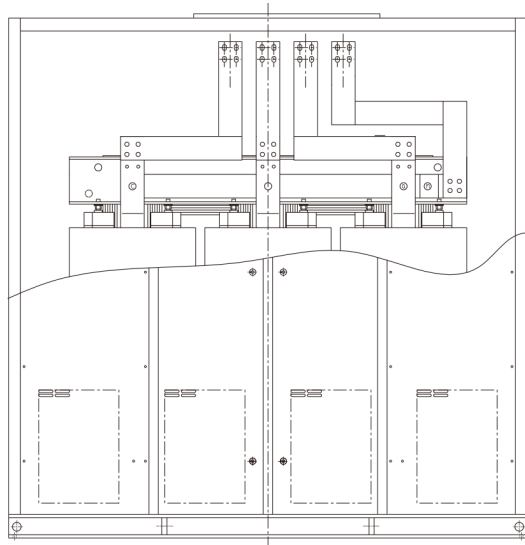

Typical Outgoing From The Top

Typical Incoming and Outgoing Connections

Cable incoming from the top or bottom and bus bar outgoing from the side

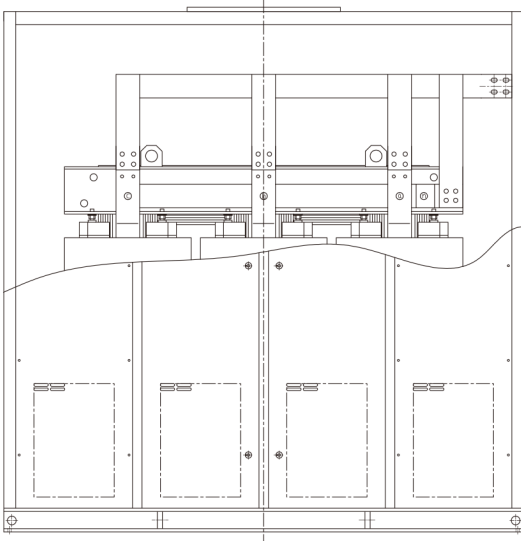

Typical Outgoing From The Side

Typical cable flanged dimension

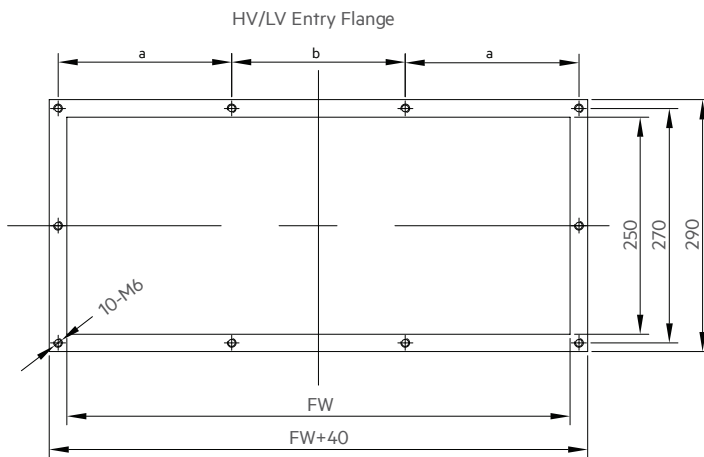

(Unit: mm)

Cable Entry Flange Dimensions			
Wheel Distance	FW	a	b
660	480	170	160
820	580	200	200
1070	680	230	240

Configurations

IP54 Enclosure

- Fans forced ventilate (Rittal)
- Stainless bolts/screws/washers
- Stainless locker (Southco)
- Silicon rubber seal
- IP4X louvers
- Outdoor paint



Configurations

Typical Electrical Drawings

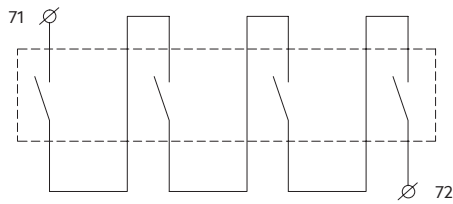
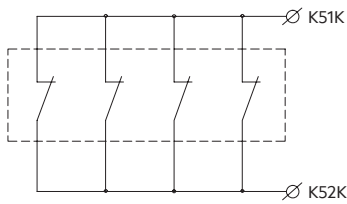
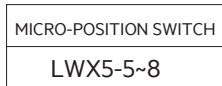
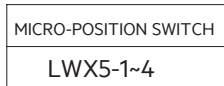
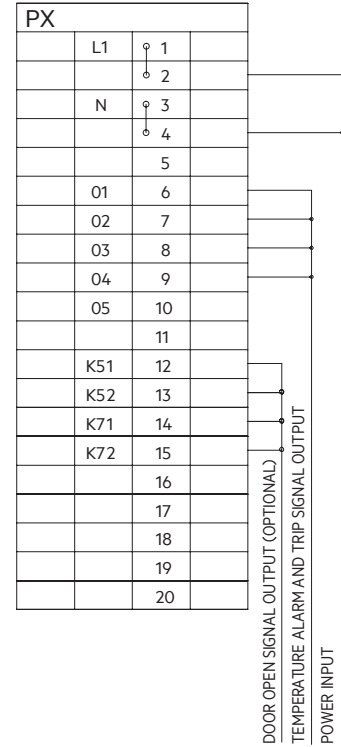
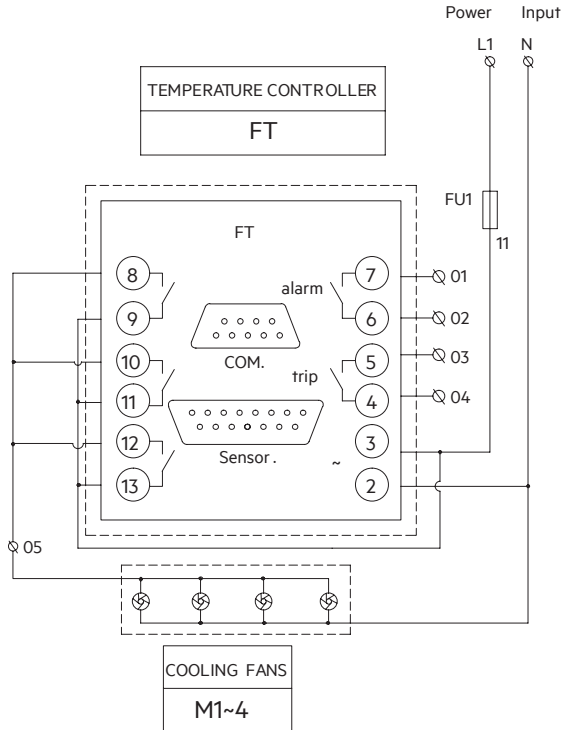

TERMINAL BLOCK:

01-02: NORMAL-OPEN CONTACT FOR ALARM

03-04: NORMAL-OPEN CONTACT FOR TRIP

K51-K52: NORMAL-CLOSE CONTACT WHEN DOOR
OPEN (OPTIONAL)

K71-K72: NORMAL-OPEN CONTACT WHEN DOOR
OPEN (OPTIONAL)

Other Information

Testing

Tests are performed in accordance with IEC60076-11:2004 or IEEE C57.12.91-2001.

Routine tests

Each cast coil transformer undergoes a complete set of routine tests to ensure reliability.

- Measurement of winding resistance
- Measurement of voltage ratio and phase displacement check
- Measurement of insulation resistance
- Measurement of short circuit impedance and load losses
- Measurement of no-load losses and current
- Separate-source AC voltage withstand voltage test
- Induced AC withstand voltage test Measurement of partial discharge

Special tests

- Sound level measurement
- Short-circuit withstand test

Type tests

A type test is performed in the event of a new design or an important design modification in order to confirm that the quality of the transformer remains compliant to related standards. Type tests can be carried out according to request.

WaveCast has passed the following tests

- Temperature-rise test
- Lightning impulse test
- Short-circuit test at KEMA Holland on 2.5MVA transformer
- All routine, type and special tests at CTQC witnessed by KEMA on 1600kVA 11/0.4kV copper winding transformer, and 2000kVA 20/0.4kV aluminum-winding transformer. (KEMA report)
- All routine, type and special tests at CTQC (China Transformer Quality Center) on 2MVA distribution transformer
- All routine, type and special tests at CTQC on 10MVA power transformer
- The C2 climatic class, E2 environmental class. F1 fire behavior class tests at CTQC
- Vibration test withstands the acceleration a_g of the horizontal 0.6g and vertical 0.3g at Tongji University

Packaging



Other Information

Handling and Transporting

Handling a transformer

1. Four (4) hoisting joint hinges are installed on the upper (channel-section) of transformer.
2. It is suggested to hoist the body integrally by 4 steel cables.
3. The angle between steel cables should not be more than 60 degrees.

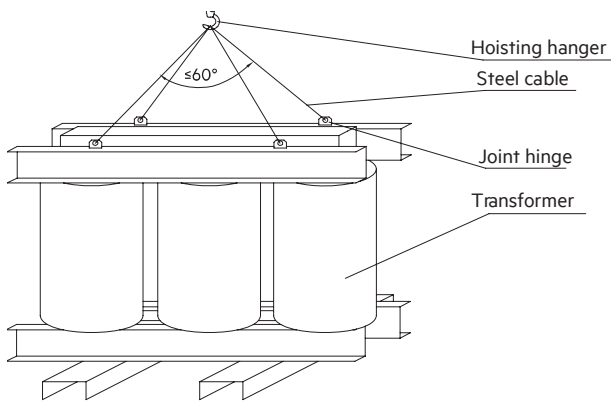

Handling a transformer

1. The 4 lifting pads are fixed on the base of the enclosure.
2. It is suggested to hoist the enclosure by 4 steel cables and spreader bar (or similar tools) as shown above.
3. The angle between steel cables should not be more than 60 degrees.

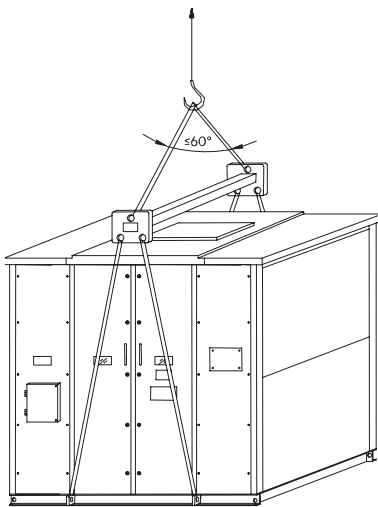

Handling transformer with enclosure

Transporting by fork-lift truck

1. The fork shall be symmetrically placed under the enclosure base to avoid inclining and overturning.
2. The fork end shall be over the enclosure center to avoid inclining and overturning.
3. The speed must be slow.

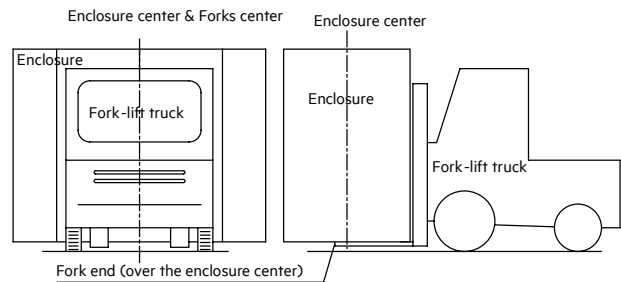
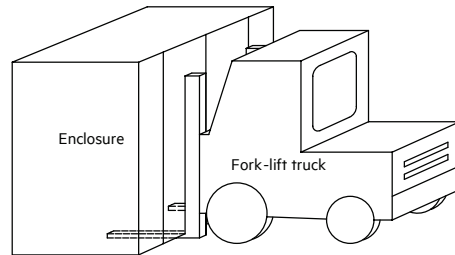

Storage

1. Transformers in storage and during non-running periods must be kept dry and away from severe moisture.
2. The relative humidity of the surrounding air must be less than 93%. No drops of water should be present on the surface of the coils.
3. For further details, refer to the Wave Cast Operating and Maintenance Manual.

Foundation Installation

(Unit: mm)

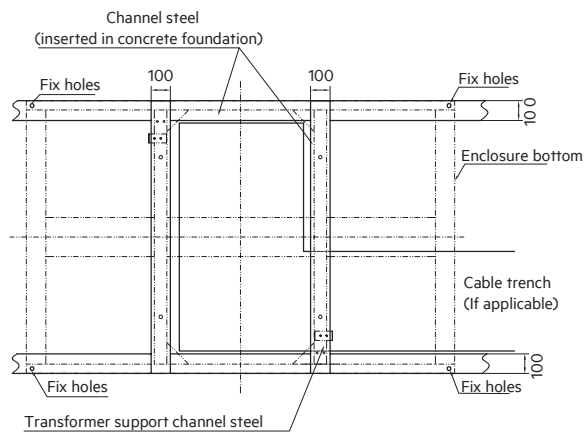
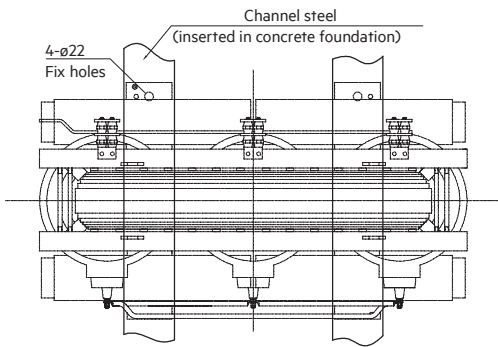
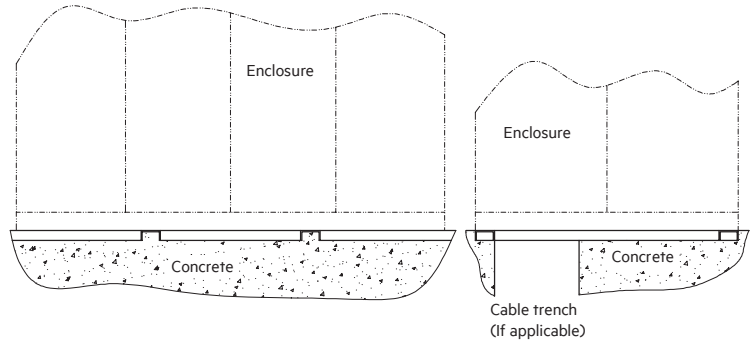
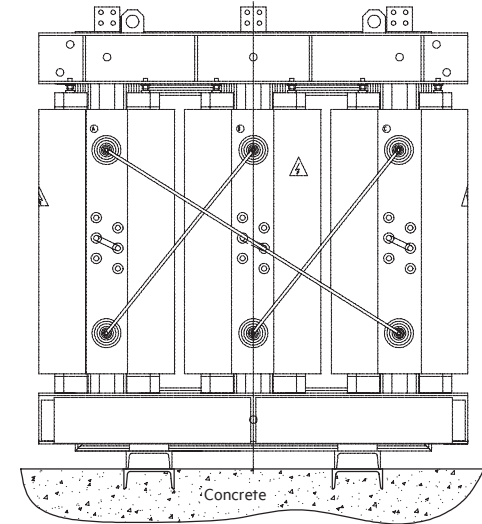

Other Information

Checklist

RFQ Transformer Checklist

Project Name _____

RFQ No.: _____

Quantity*	_____ units	Capacity*	_____ kVA
Phase Number*	<input type="checkbox"/> Three phase		
Frequency*	<input type="checkbox"/> 50Hz	<input type="checkbox"/> 60Hz	
Applicable standard*	<input type="checkbox"/> IEC 60076-11	<input type="checkbox"/> IEEE C57.12.01	
Winding material*	<input type="checkbox"/> Copper	<input type="checkbox"/> Aluminum	
Rated voltage (No-load voltage)*	High Voltage _____ kV	Low Voltage _____ kV	
Connection Symbol*	<input type="checkbox"/> Dyn11	<input type="checkbox"/> Dyn5	<input type="checkbox"/> Yyn0 <input type="checkbox"/> Others: _____
Short circuit impedance*	<input type="checkbox"/> 4%	<input type="checkbox"/> 6%	<input type="checkbox"/> Others: _____
Insulation class*	<input type="checkbox"/> F	<input type="checkbox"/> H	<input type="checkbox"/> Others: _____
Temperature rise	<input type="checkbox"/> IEC standards	<input type="checkbox"/> IEEE standards	<input type="checkbox"/> Others: _____
Tap Changing method	<input type="checkbox"/> Off-circuit tap changing	Tapping range: <input type="checkbox"/> $\pm 2 \times 2.5\%$	<input type="checkbox"/> $\pm 5\%$ <input type="checkbox"/> Others: _____
	<input type="checkbox"/> On-load tap changing	Tapping range: <input type="checkbox"/> $\pm 4 \times 2.5\%$	<input type="checkbox"/> $\pm 3 \times 2.5\%$ <input type="checkbox"/> Others: _____
		On-load tap changer location	<input type="checkbox"/> front <input type="checkbox"/> side
Temperature control device	<input type="checkbox"/> No.	<input type="checkbox"/> Yes, BWD-3K130	<input type="checkbox"/> with RS485 interface <input type="checkbox"/> with 4-20mA output
Cooling*	<input type="checkbox"/> Air natural (AN)		<input type="checkbox"/> Air forced (AF)
Controller/fans voltage	<input type="checkbox"/> 220V AC (1 phase 50Hz)	<input type="checkbox"/> 110V AC (1 phase 60Hz)	<input type="checkbox"/> Others: _____
Service condition	Altitude*	<input type="checkbox"/> not more than 1000 meter	<input type="checkbox"/> Others _____ meter
	Max. temp.*	<input type="checkbox"/> 40°C	<input type="checkbox"/> Others _____ °C
	Min. temp	<input type="checkbox"/> -5°C (Indoors)	<input type="checkbox"/> -30°C (Outdoors)
	Indoor/outdoor*	<input type="checkbox"/> Indoor	<input type="checkbox"/> Outdoor
	Environmental*	<input type="checkbox"/> Normal	<input type="checkbox"/> Corrosive area (coast, offshore etc.)
Enclosure protection class*	<input type="checkbox"/> IP00	<input type="checkbox"/> IP20	<input type="checkbox"/> IP21 <input type="checkbox"/> IP23 <input type="checkbox"/> Others: _____
Enclosure material*	<input type="checkbox"/> Steel sheet	<input type="checkbox"/> A1 alloy sheet	<input type="checkbox"/> Stainless steel sheet
Enclosure color	<input type="checkbox"/> RAL 7032	<input type="checkbox"/> RAL 7035	<input type="checkbox"/> ANSI 61 <input type="checkbox"/> Customer templet <input type="checkbox"/> Others: _____
Incoming type(HV)*	<input type="checkbox"/> Cable incoming		<input type="checkbox"/> Busbar incoming
	<input type="checkbox"/> Top input	<input type="checkbox"/> Bottom input	<input type="checkbox"/> Side input <input type="checkbox"/> Others: _____
Outgoing type(LV)*	<input type="checkbox"/> Cable outgoing		<input type="checkbox"/> Busbar outgoing
	<input type="checkbox"/> Top output	<input type="checkbox"/> Bottom output	<input type="checkbox"/> Side output <input type="checkbox"/> Others: _____
Shipment(TR & enclosure)	Shipping together		Shipping separately
Rollers (temporary move)	<input type="checkbox"/> Yes	<input type="checkbox"/> NO	
Other special requirements			

Note: Required fields are indicated by * .

If the transformer cubicle is connected to the HV and LV breaker, the interface drawings for HV&LV and Plan Arrangement should be provided, including the contents described as follows:

1. The shape and dimension of HV/LV cubicle (enclosure dimension)
2. Size, quantity, location, and phase sequence of Busbar or cable
3. The dimension, quantity and location of the connection holes vvhich connect to transformer cubicle
4. The arrangement mode and alignment mode of HV/LV cubicles with transformer cubicles

Standard package is vacuum bag wrap inside wooden box and equipped with shock watch to monitor transportation impact. If change the shipment mode after manufacturing, all the addition cost caused by those change are borne by the customers.

GEIS

GEIS Electric

Website: www.geis.tech

Hotline: +86 400-820-5234

This catalog may be subjected to revision without prior notice.
Version No.: GENCLVAV26V1

